



US010202797B1

(12) **United States Patent Header**

(10) **Patent No.:** US 10,202,797 B1
(45) **Date of Patent:** Feb. 12, 2019

(54) **INFILL PANEL AND OPERABLE FENESTRATION FRAME ADJUSTMENT DEVICE**

3,780,472 A 12/1973 Biebuyck
3,992,833 A 11/1976 Hulinsky
4,397,124 A 8/1983 Redman
4,671,016 A 6/1987 Boeckx
4,763,453 A 8/1988 Hogan, Jr.
4,920,717 A * 5/1990 Hooper, Jr. E04F 11/1851
52/204.597

(71) Applicant: **Gregory A Header**, Richland, PA (US)

(72) Inventor: **Gregory A Header**, Richland, PA (US)

(Continued)

(*) Notice: Subject to any disclaimer, the term of this patent is extended or adjusted under 35 U.S.C. 154(b) by 0 days.

FOREIGN PATENT DOCUMENTS

AU 2004202244 A1 3/2005
DE 1282282 B 11/1968

(Continued)

(21) Appl. No.: **15/844,326**

(22) Filed: **Dec. 15, 2017**

OTHER PUBLICATIONS

(51) **Int. Cl.**
E06B 3/54 (2006.01)
E06B 3/72 (2006.01)
E06B 3/26 (2006.01)

Who Gets the Blame when an Expensive Show-Window is Broken? Advertisement from the Zouri Drawn Metals company, Chicago Heights, IL, The American Contractor Magazine, p. 95, Apr. 15, 1916.

(Continued)

(52) **U.S. Cl.**
CPC *E06B 3/5409* (2013.01); *E06B 3/26* (2013.01); *E06B 3/72* (2013.01)

Primary Examiner — Brent W Herring
(74) *Attorney, Agent, or Firm* — Stone Creek Services LLC; Alan M Flum

(58) **Field of Classification Search**
CPC E06B 3/5409; E06B 3/26; E06B 3/72
USPC ... 52/204.5, 204.53, 204.62, 204.64, 204.65, 52/204.72, 204.1

See application file for complete search history.

(57) **ABSTRACT**

A system for adjusting infill panel or operable fenestration frame in an operable fenestration. The system can include a setting block adjustment device and an operable fenestration frame such as a door rail or window sash with glass, acrylic, polycarbonate or other infill material. The setting block adjustment device can include a lug, a threaded fastener, a setting block support plate, and a setting block. The lug is slidably captive within a groove in an outer face of the operable fenestration. The threaded fastener engages a threaded aperture within a blind hole in the lug. The fastener end engages the setting block support plate and setting block to adjust the infill panel.

(56) **References Cited**

U.S. PATENT DOCUMENTS

1,138,499 A 5/1915 Murnane
1,995,819 A 3/1935 Rogers
2,460,391 A 6/1944 Miller
2,442,147 A * 5/1948 Recklitis E05D 13/08
49/418
2,518,969 A 8/1950 Woodard
2,610,369 A 9/1952 Huizenga
2,707,536 A 5/1955 Wooten
3,404,501 A 10/1968 Von Wedel
3,413,761 A 12/1968 Proni

20 Claims, 31 Drawing Sheets

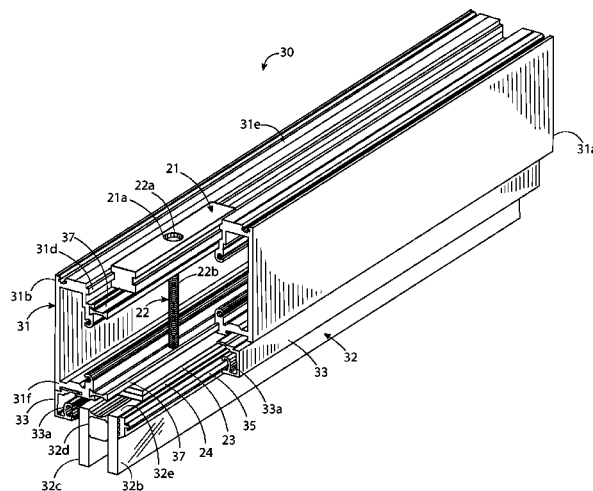
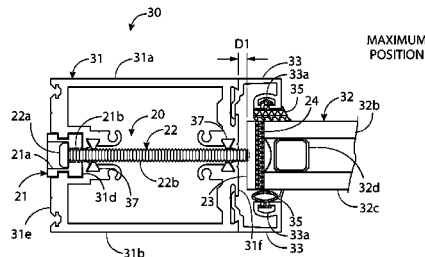

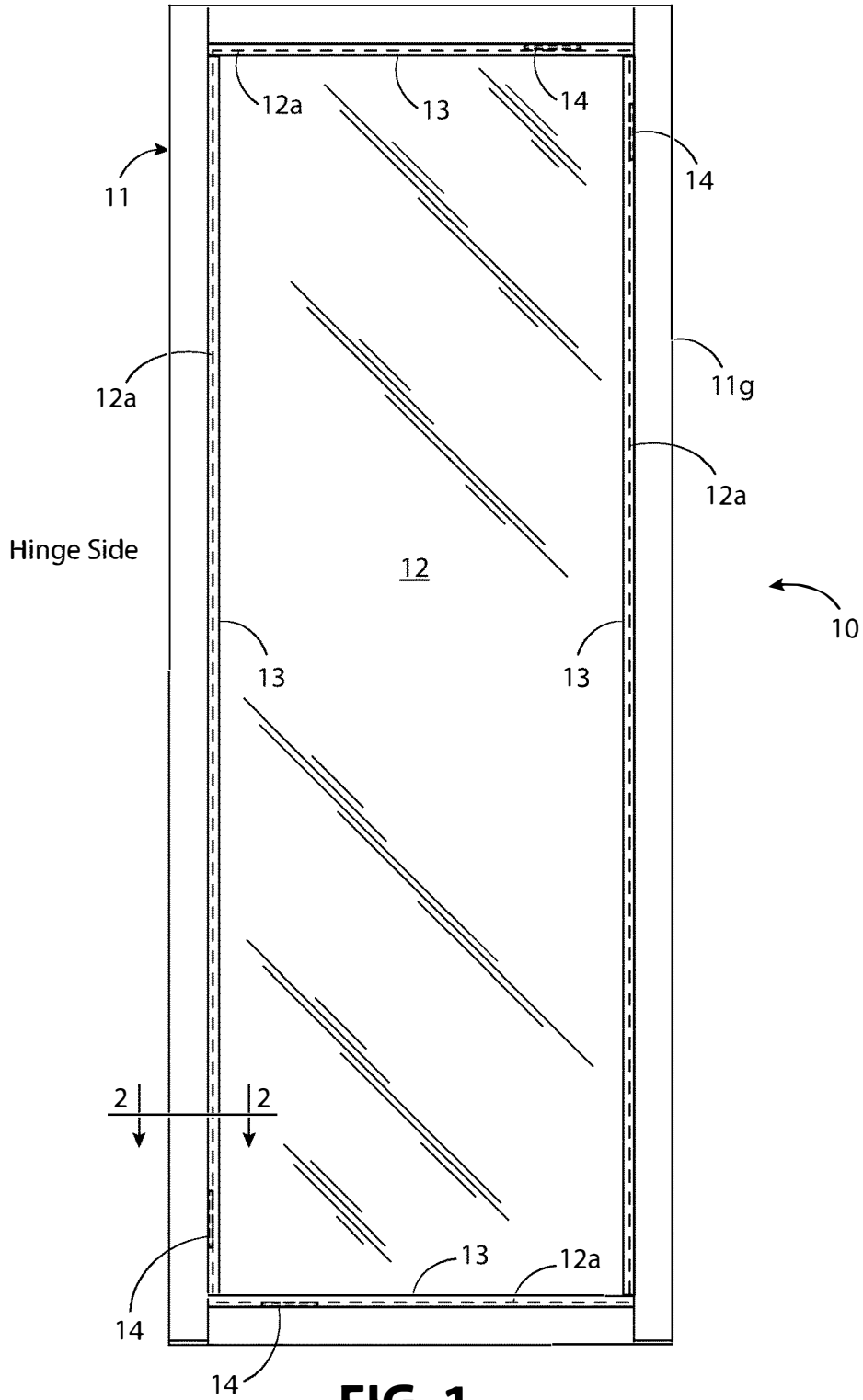

FIG. 1
PRIOR ART

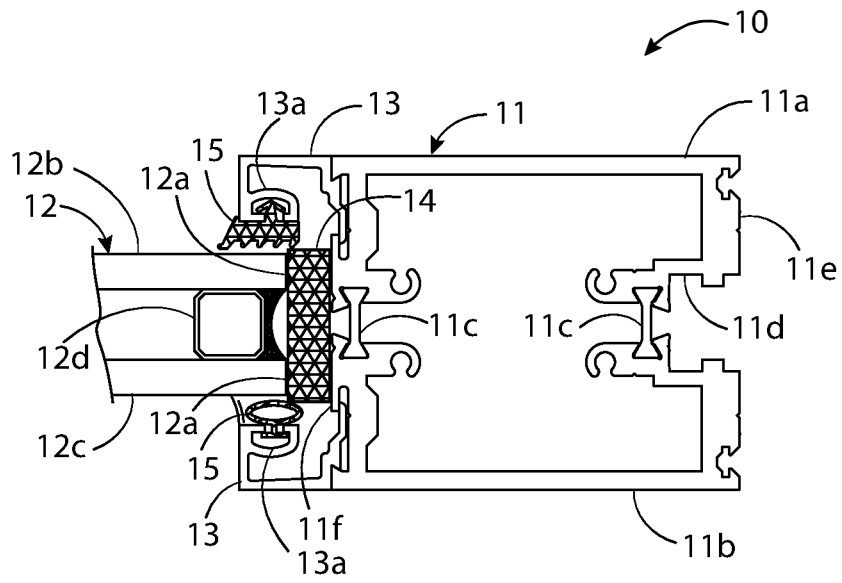

FIG. 2
PRIOR ART

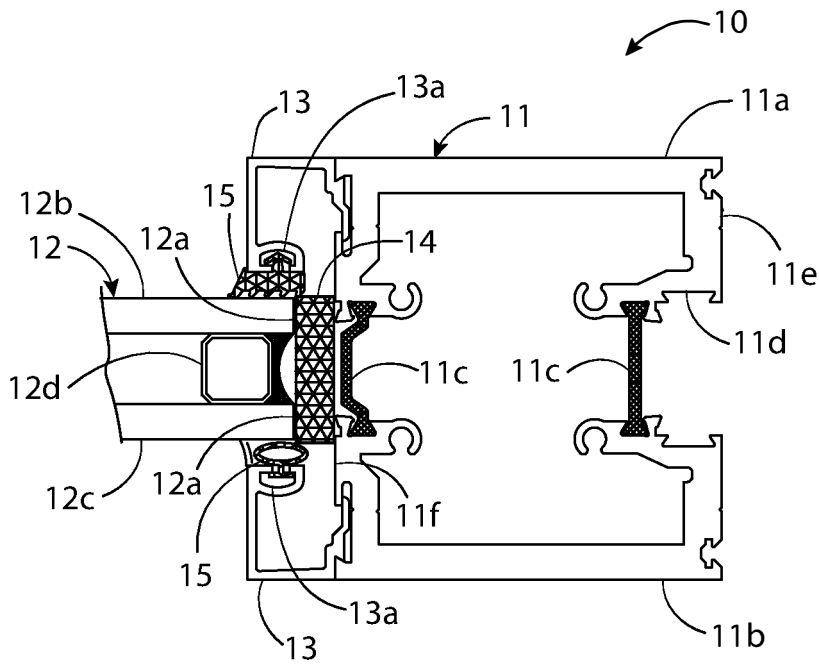

FIG. 3
PRIOR ART

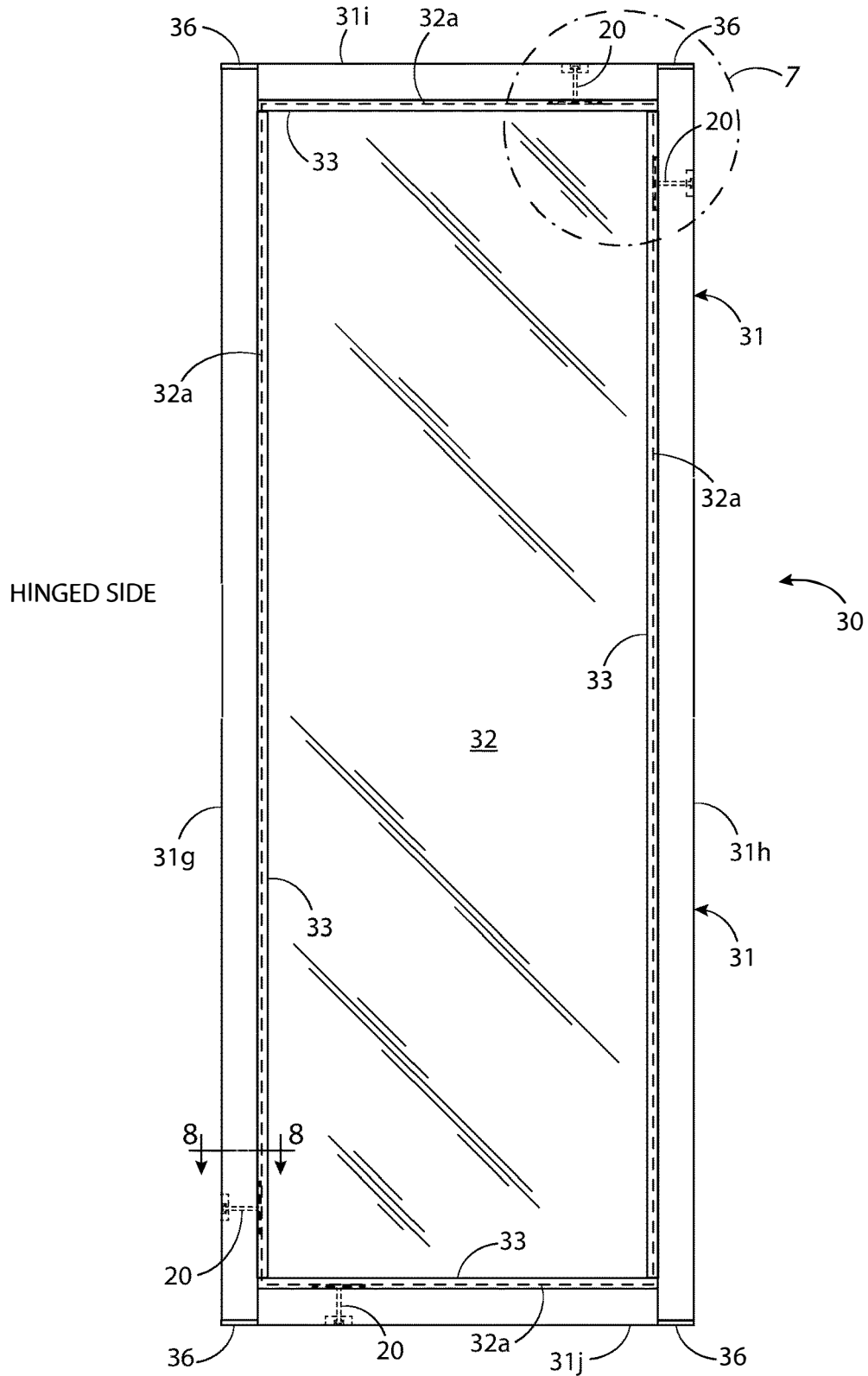

FIG. 4

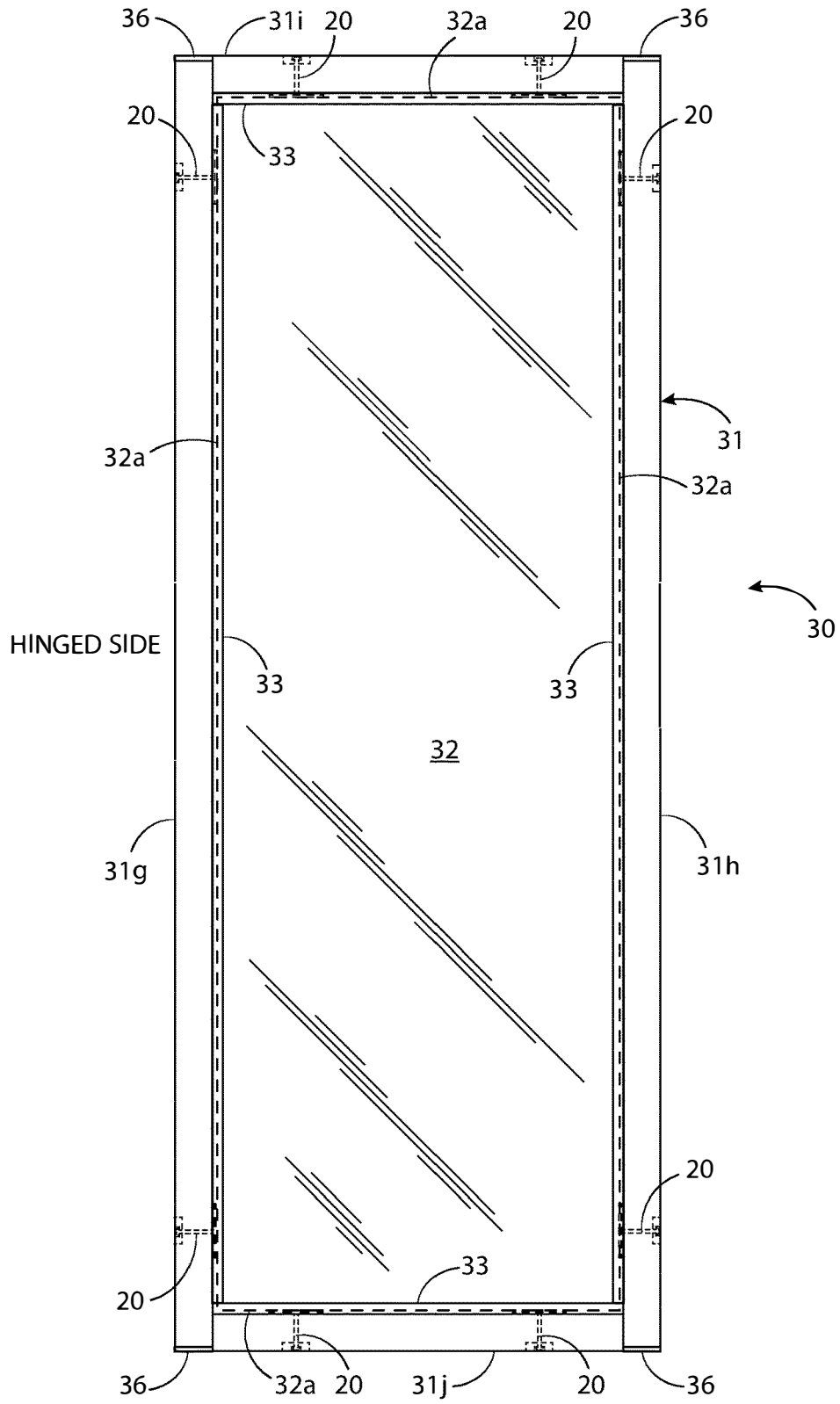

FIG. 5

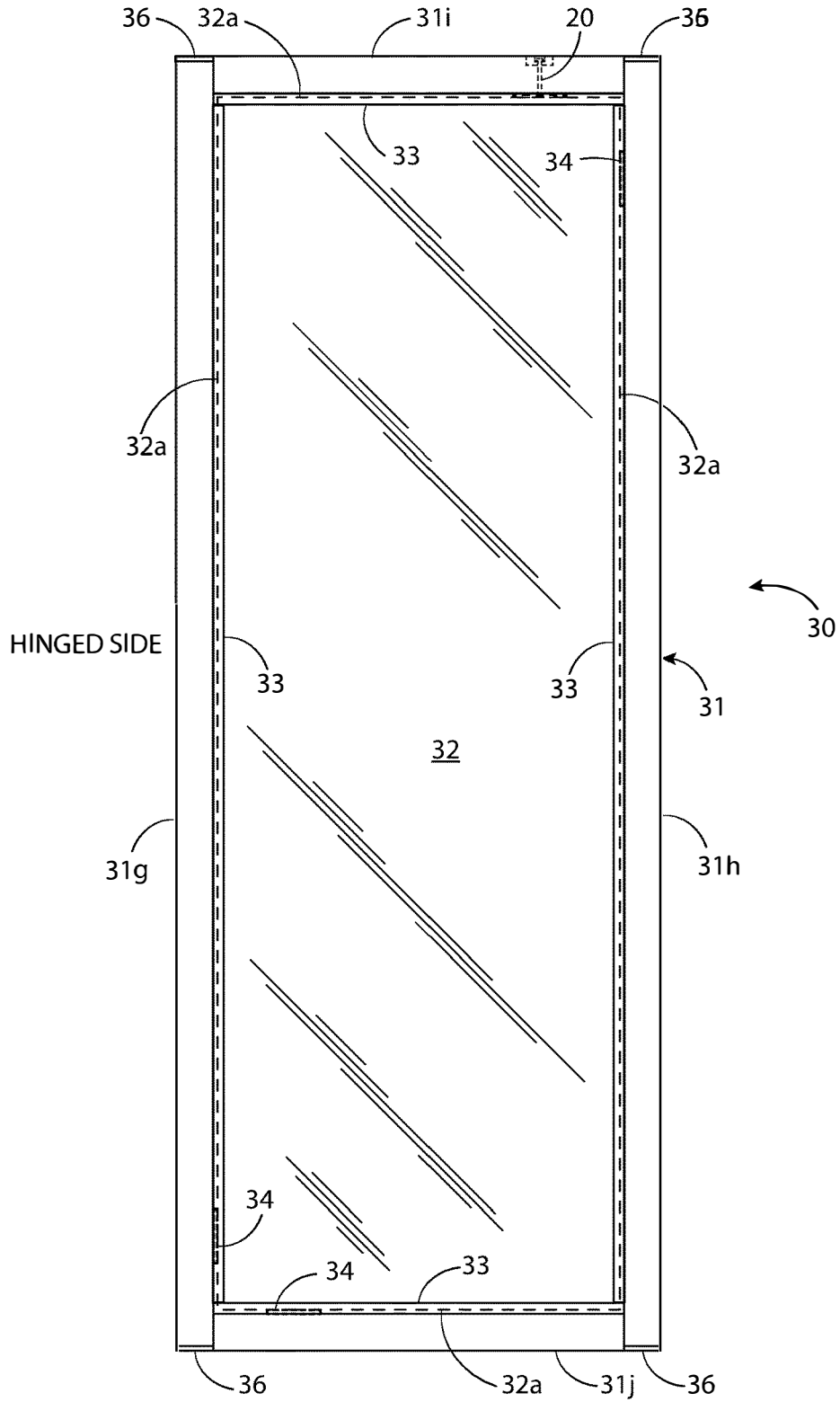

FIG. 6

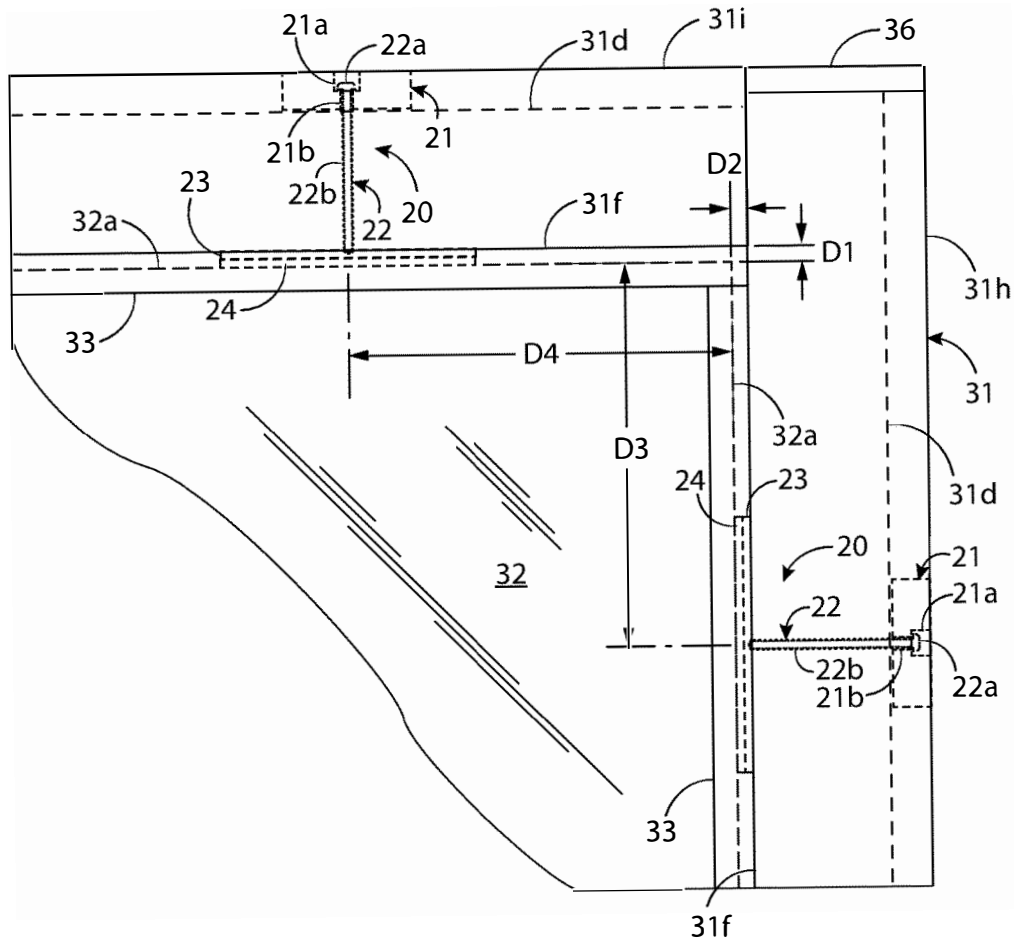

FIG. 7

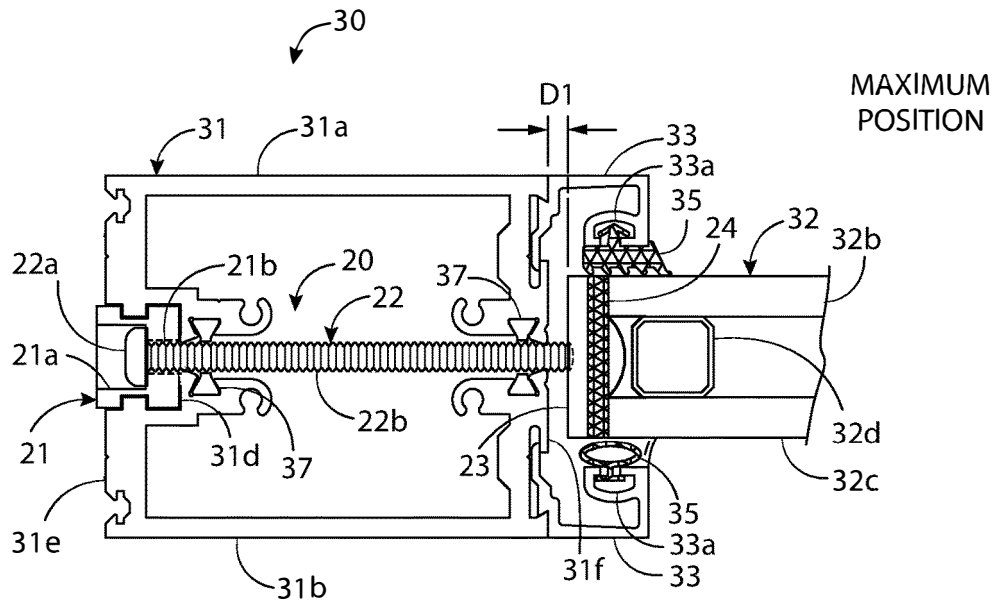

FIG. 8

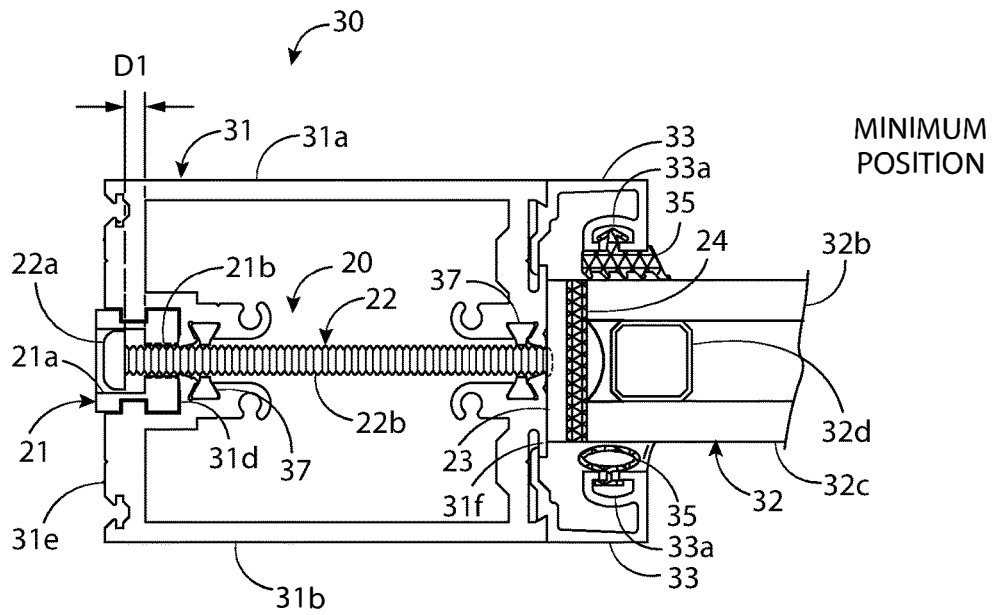

FIG. 9

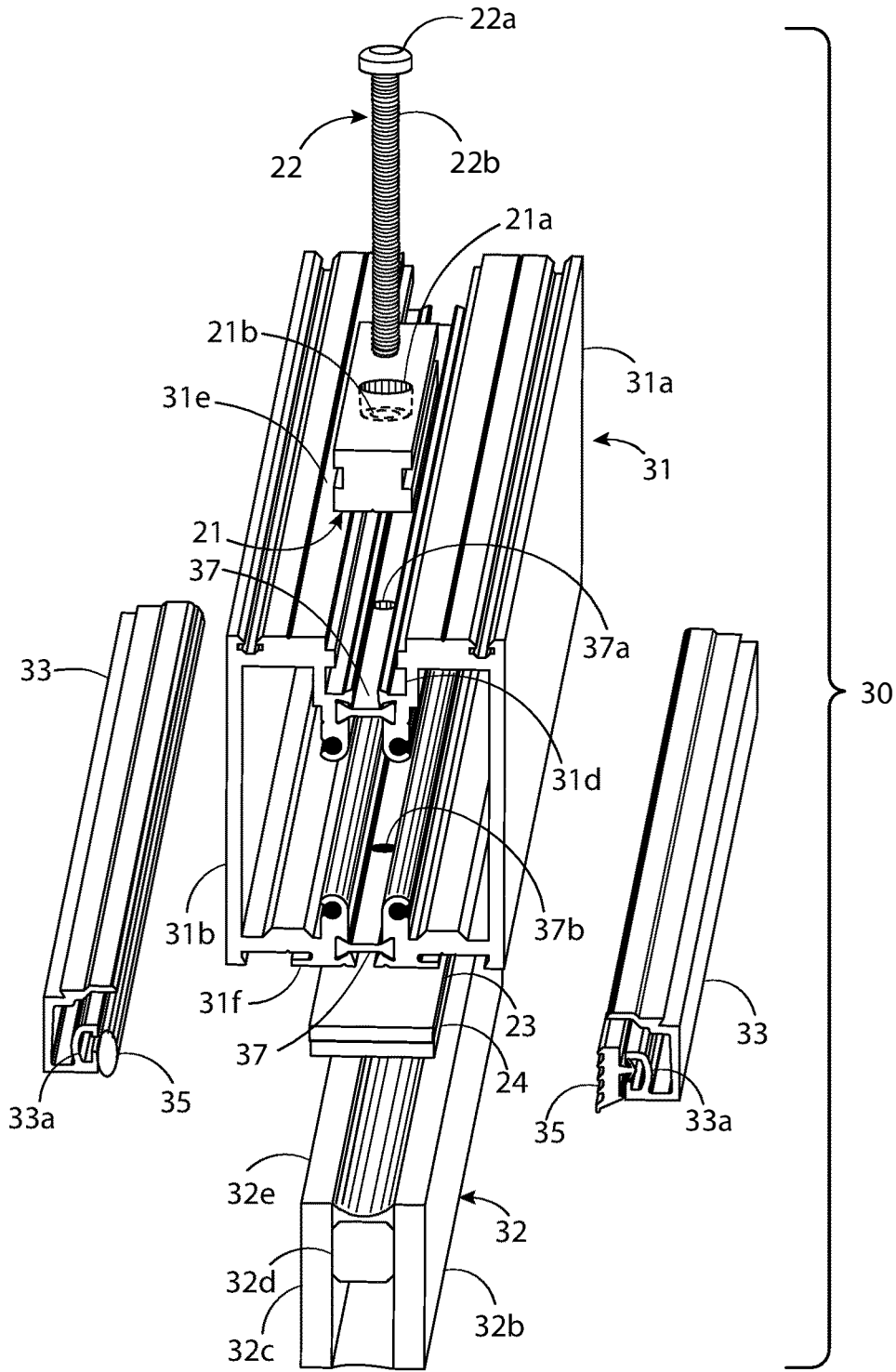

FIG. 11

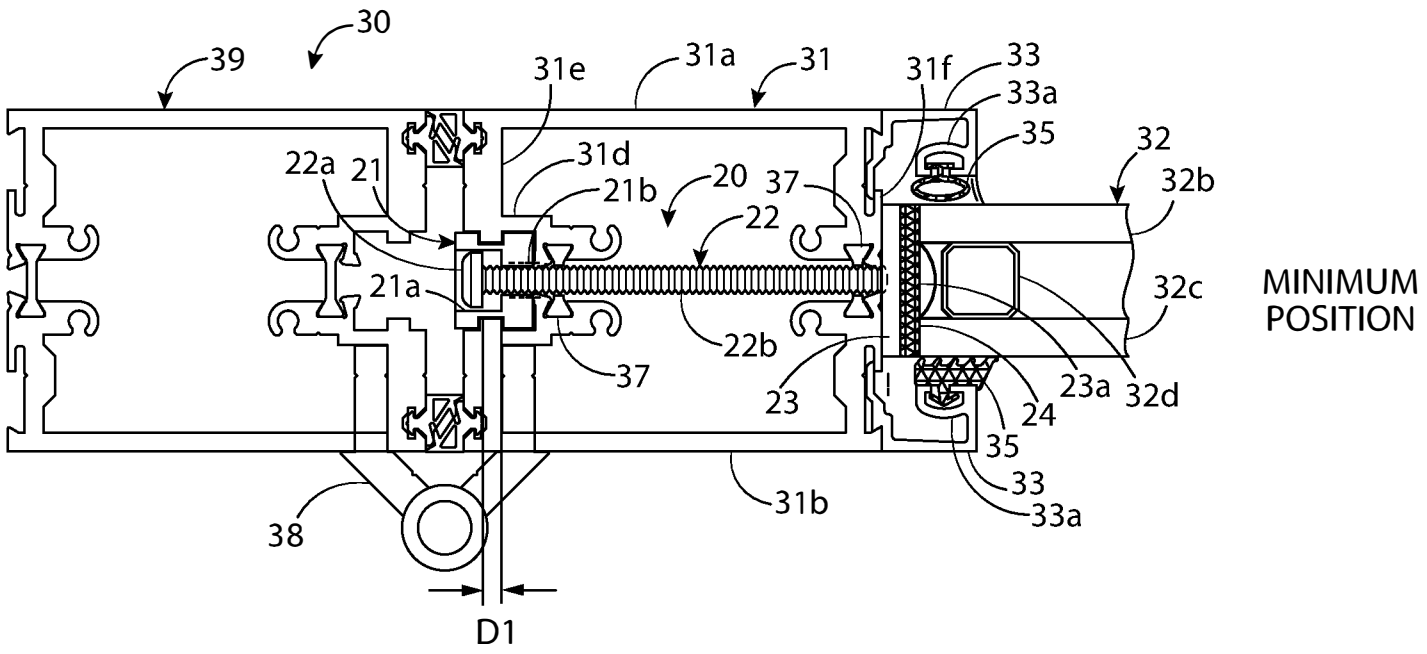
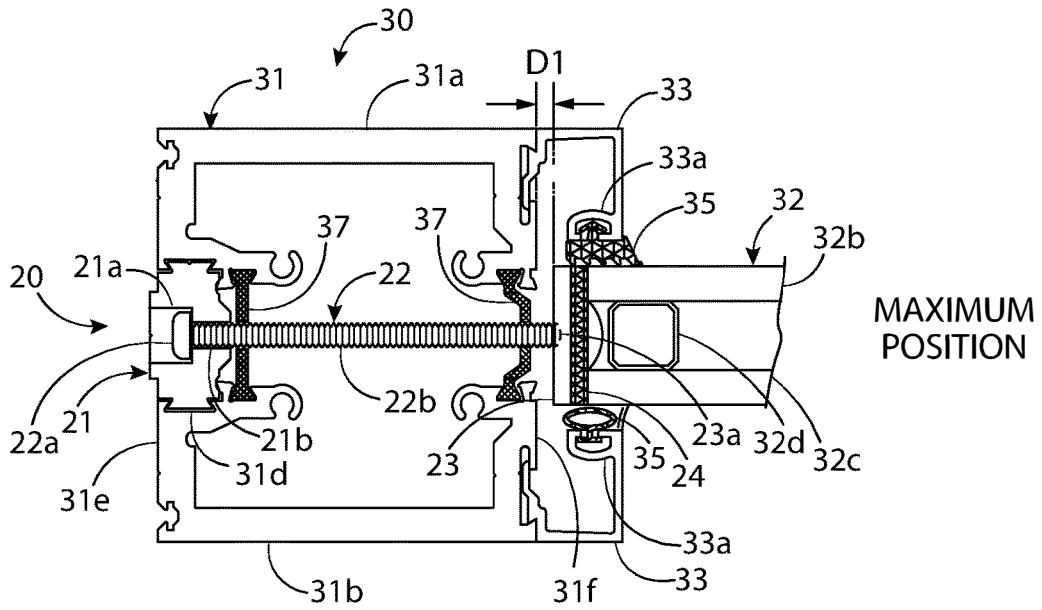

FIG. 14



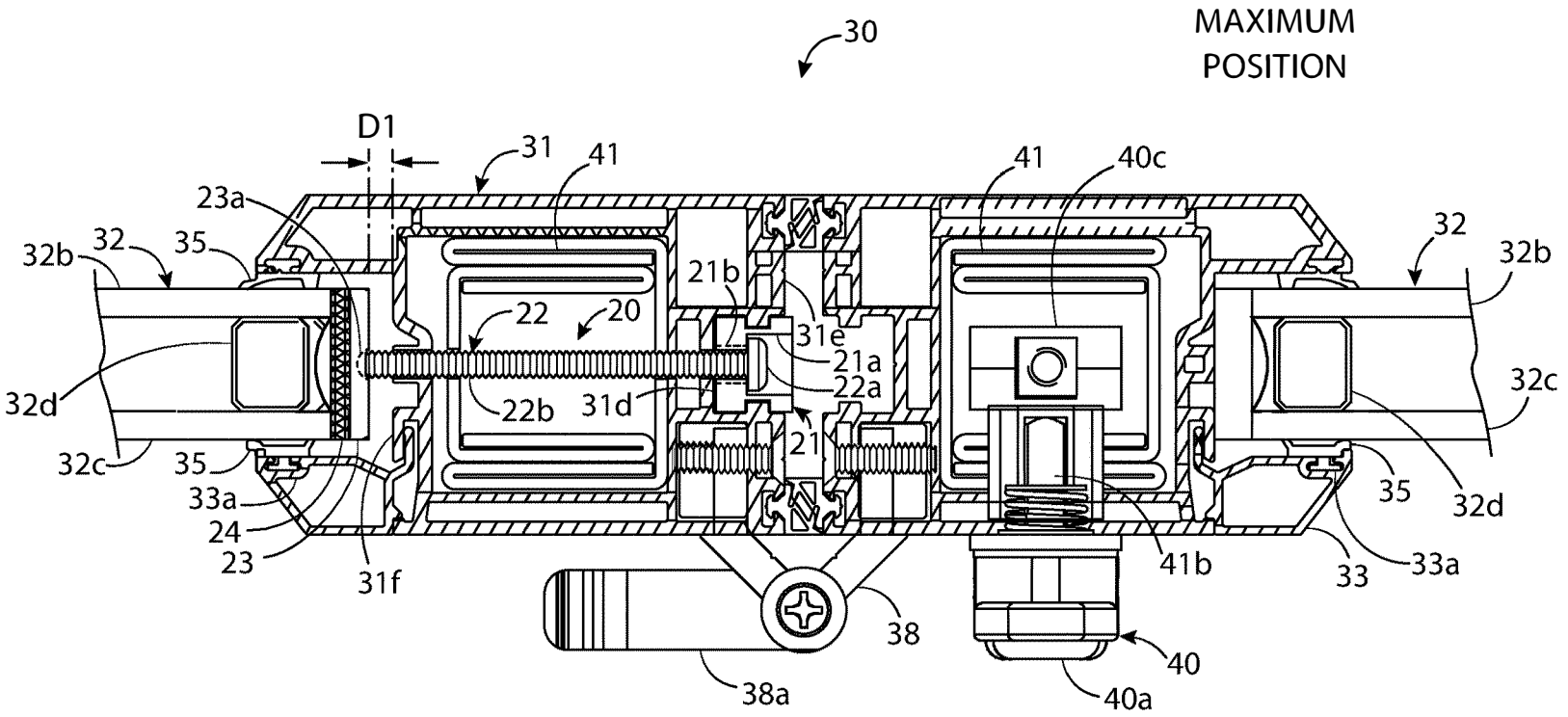

FIG. 17

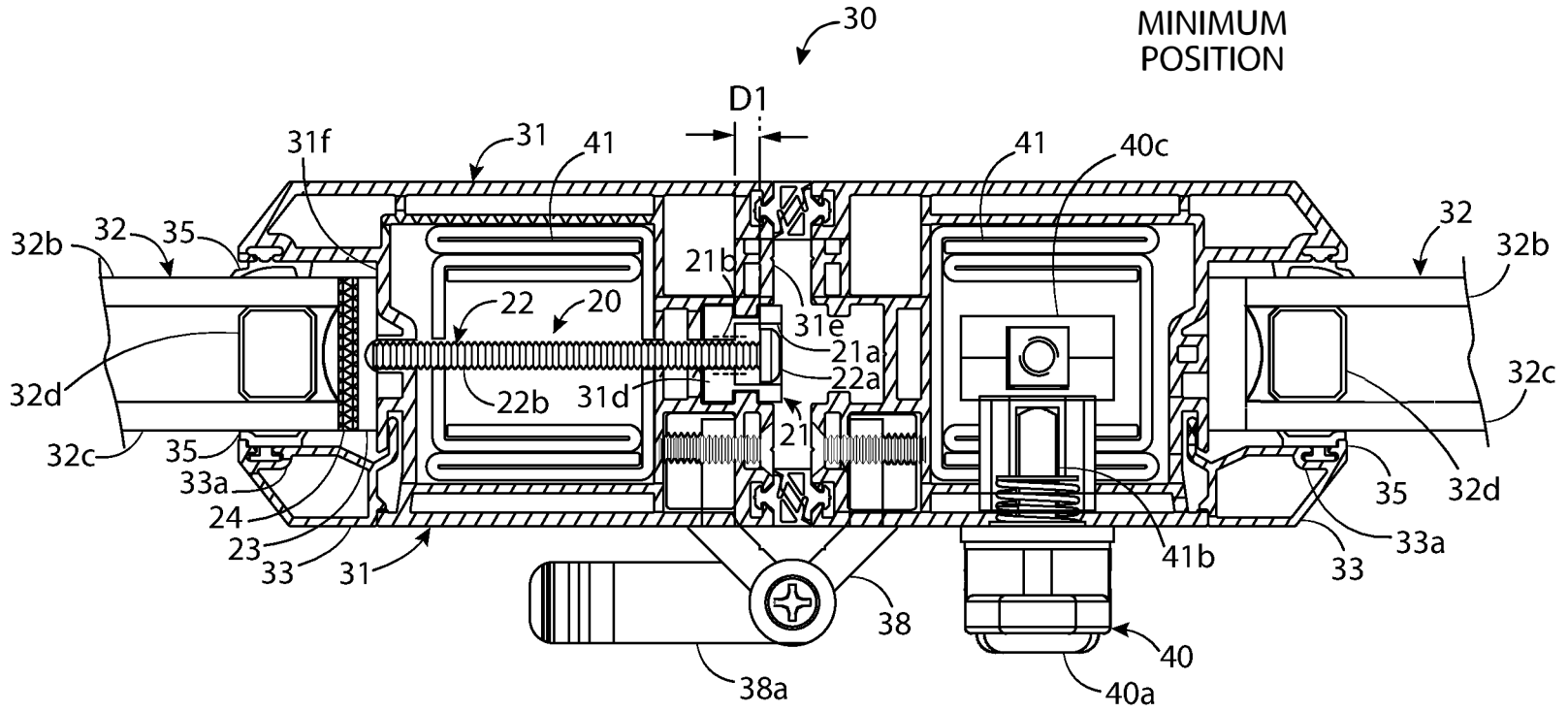

FIG. 18

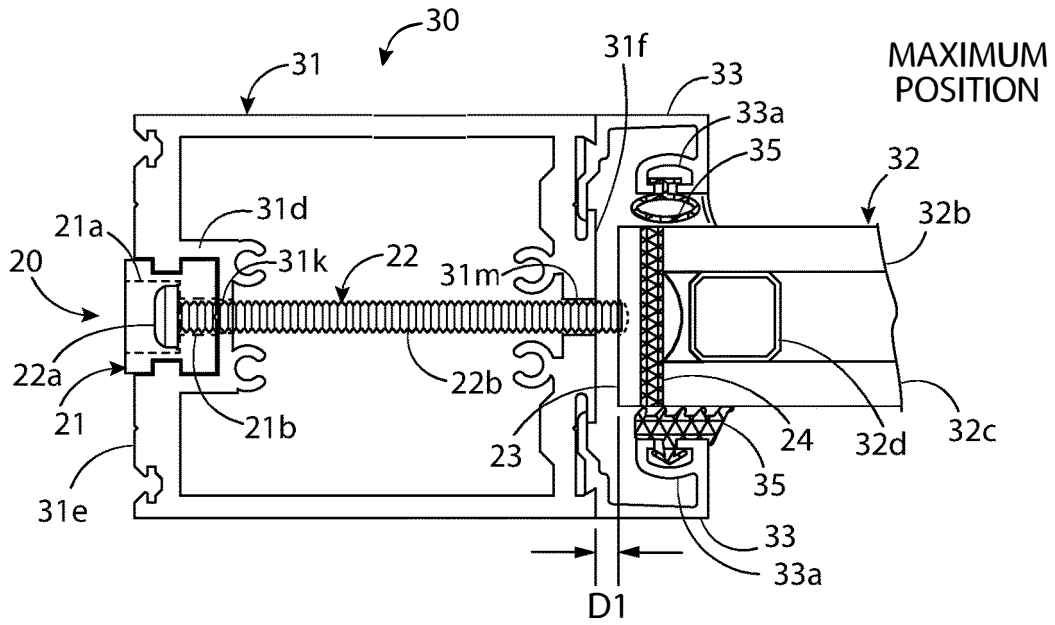

FIG. 19

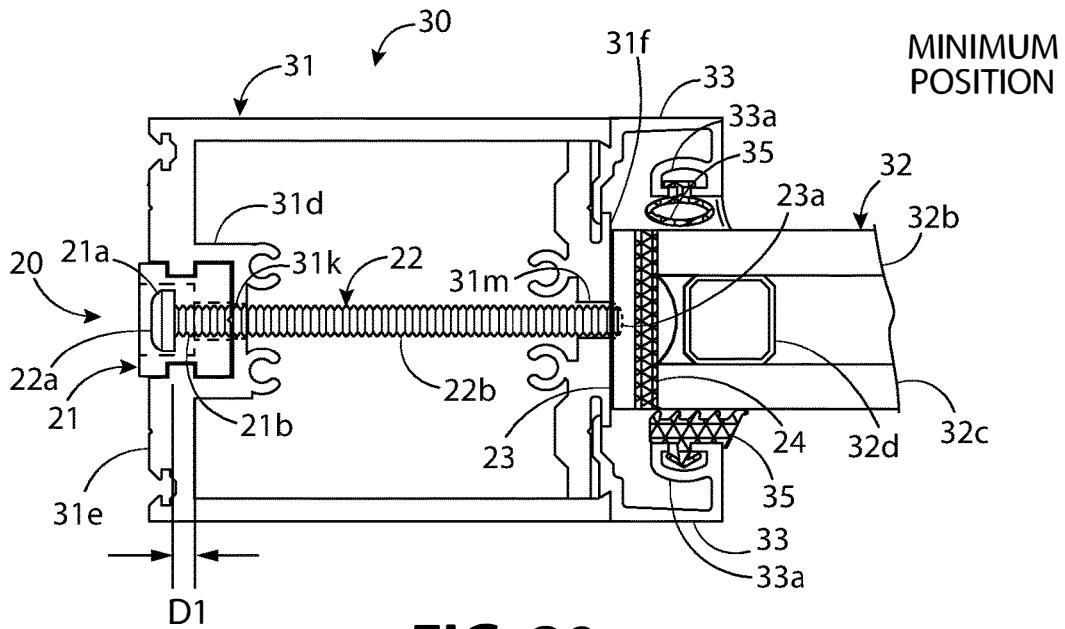

FIG. 20

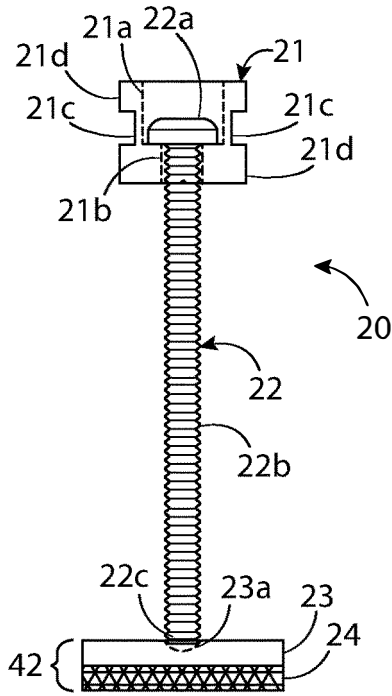

FIG. 22

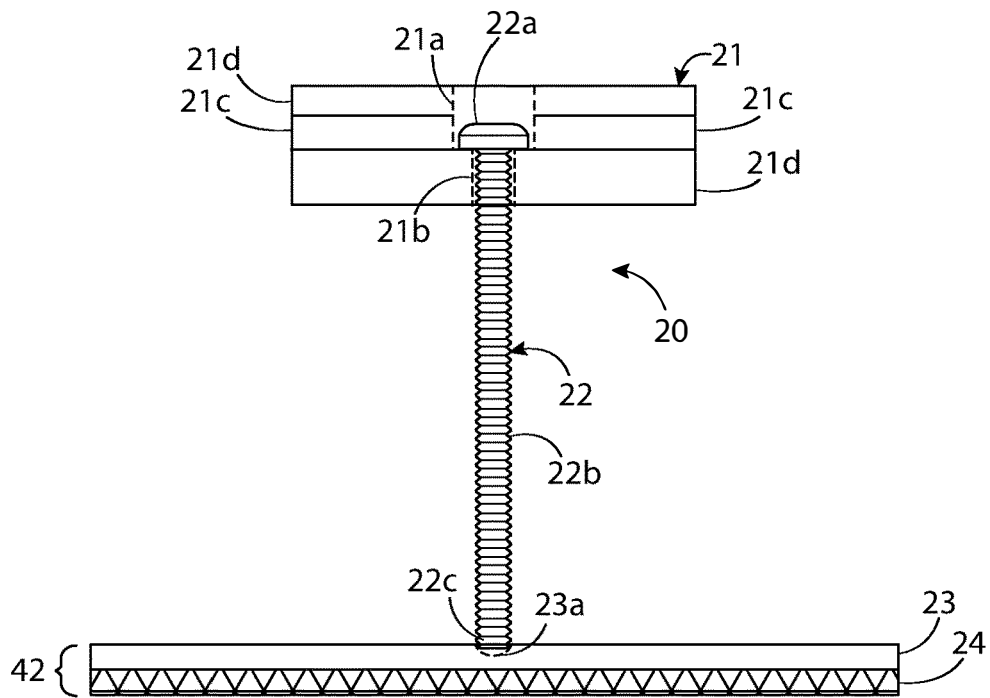

FIG. 23

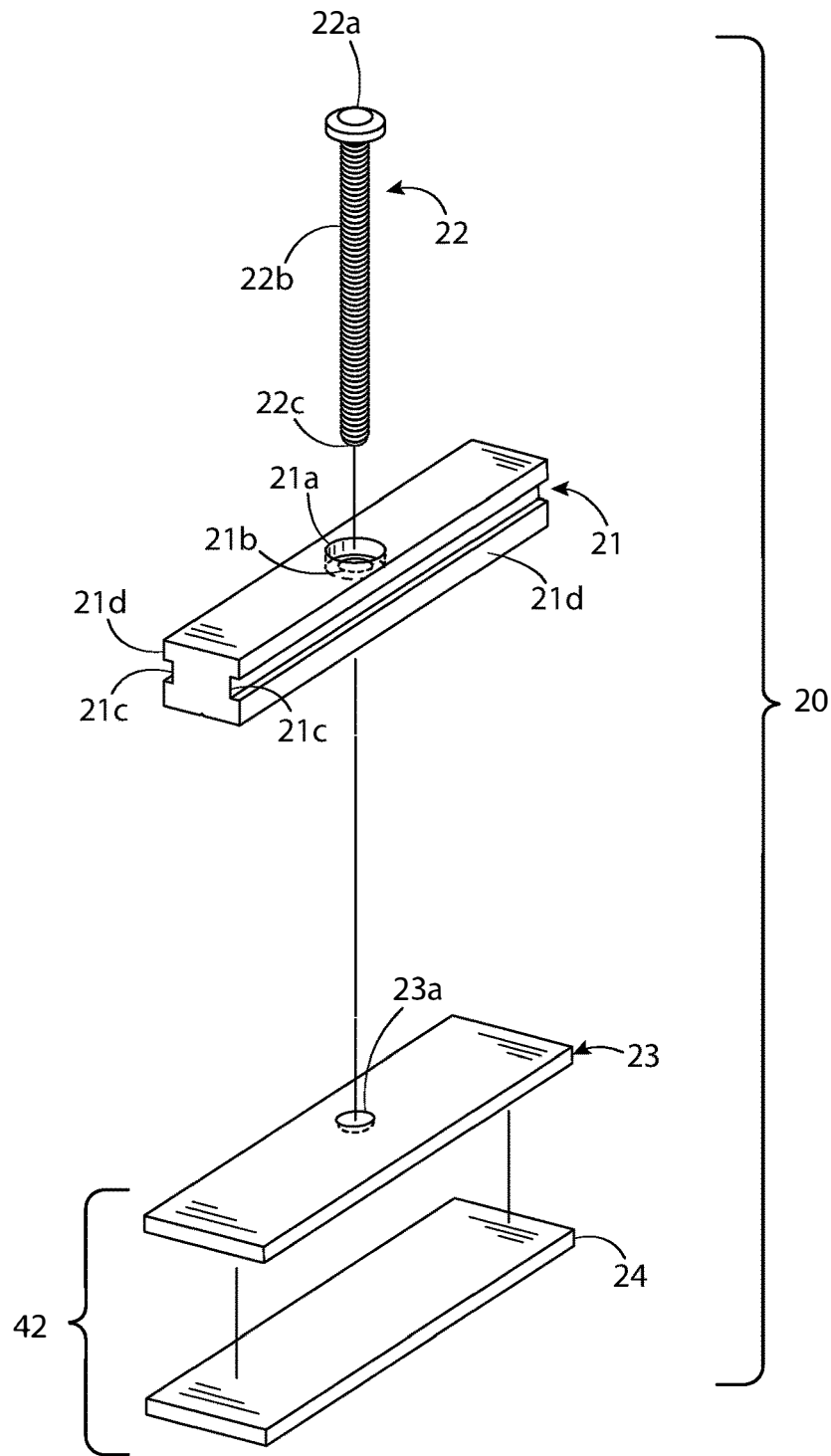

FIG. 24

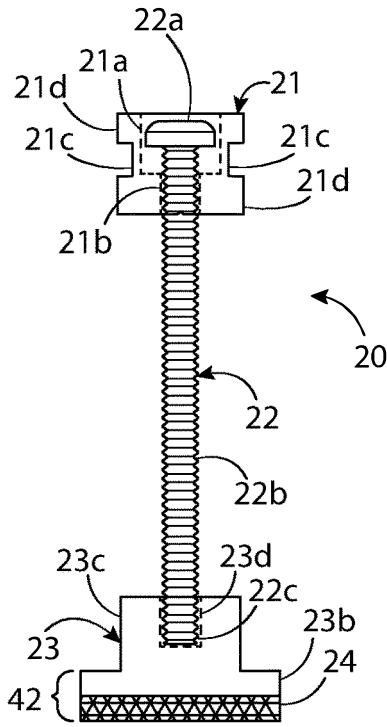

FIG. 25

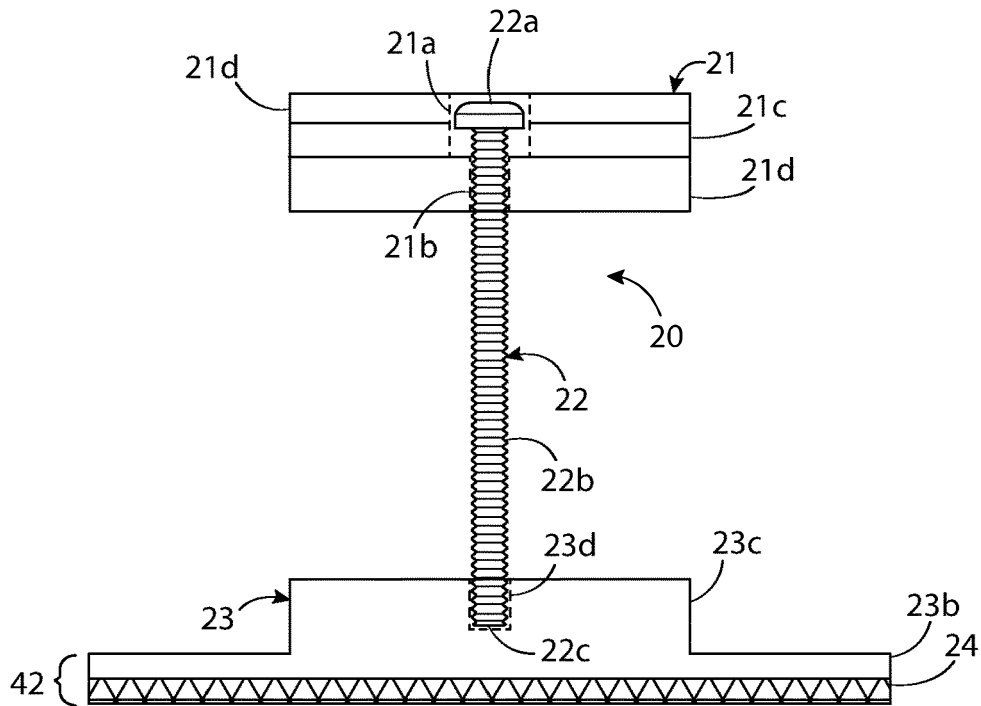

FIG. 26

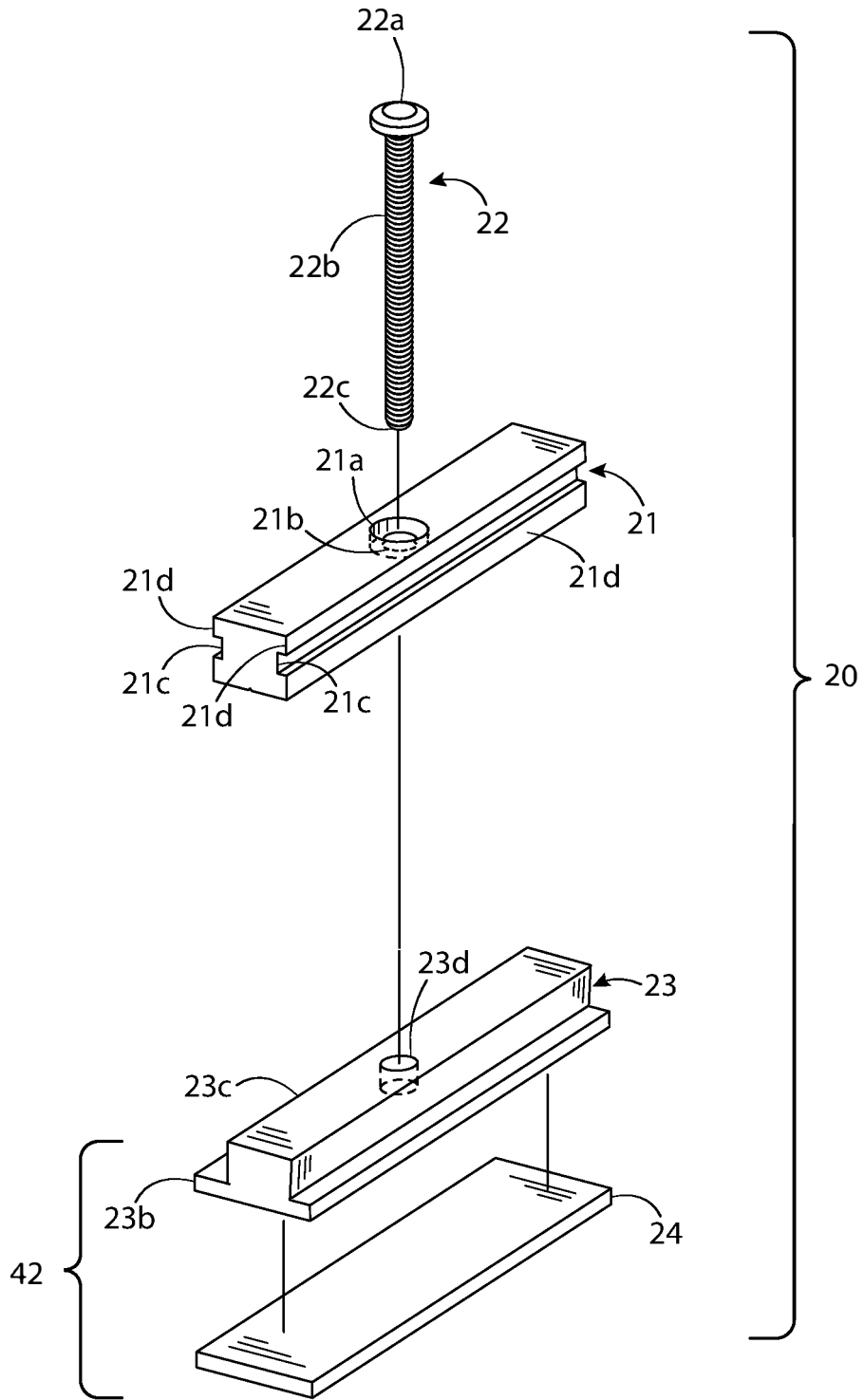

FIG. 27

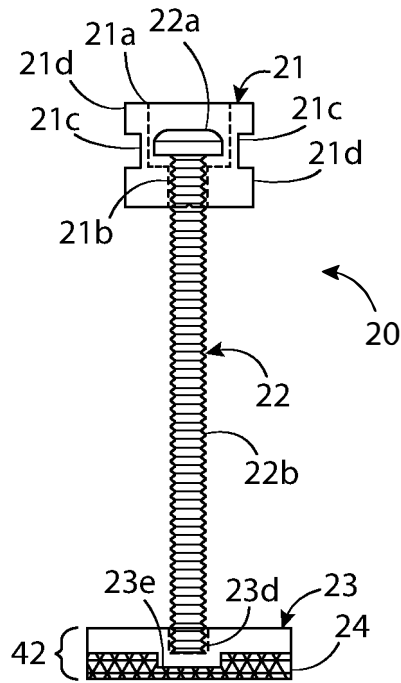

FIG. 28

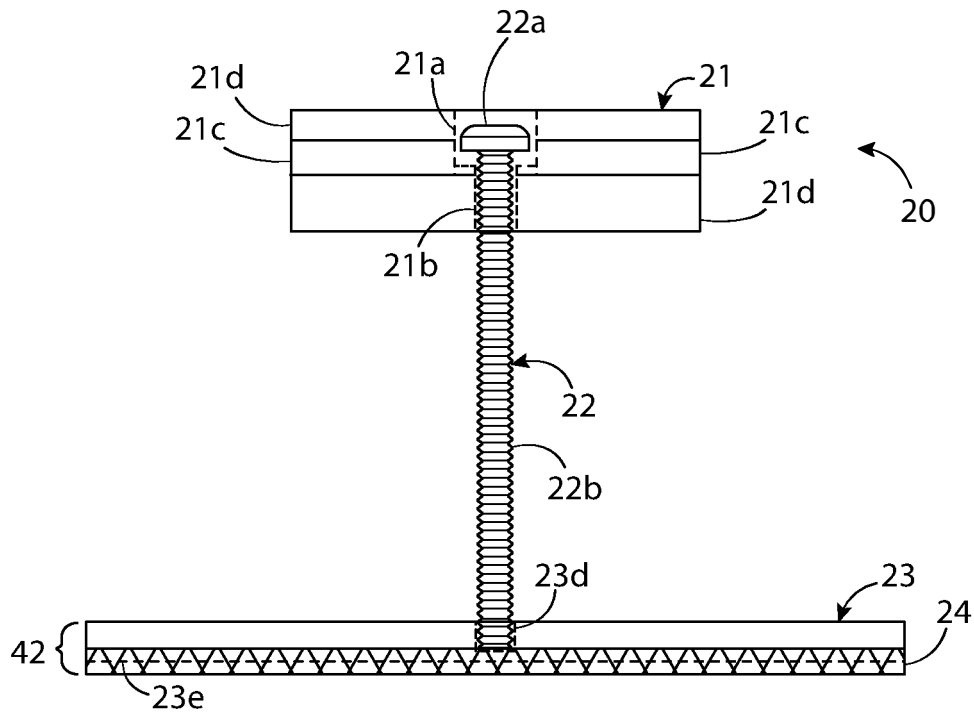

FIG. 29

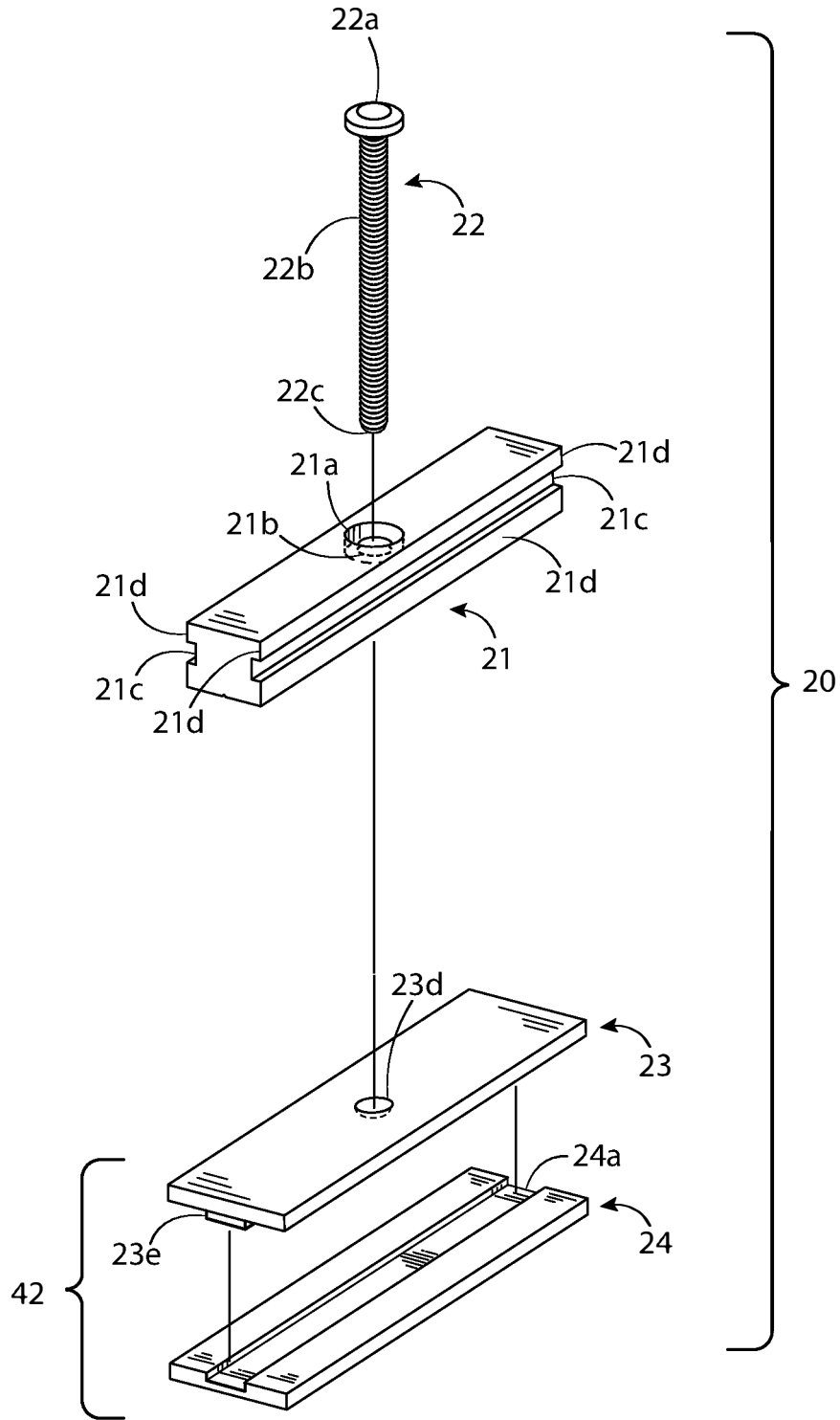

FIG. 30

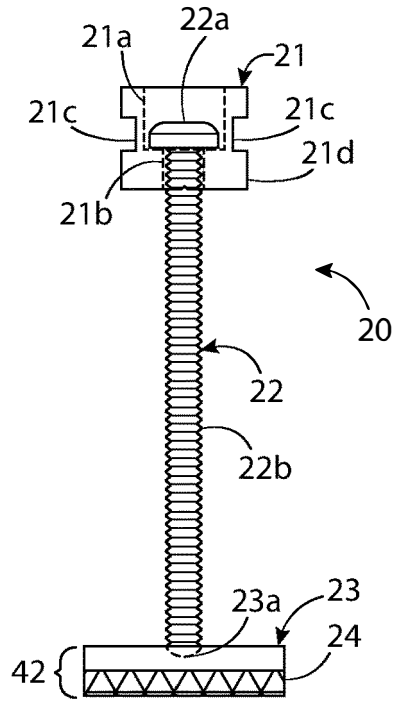

FIG. 31

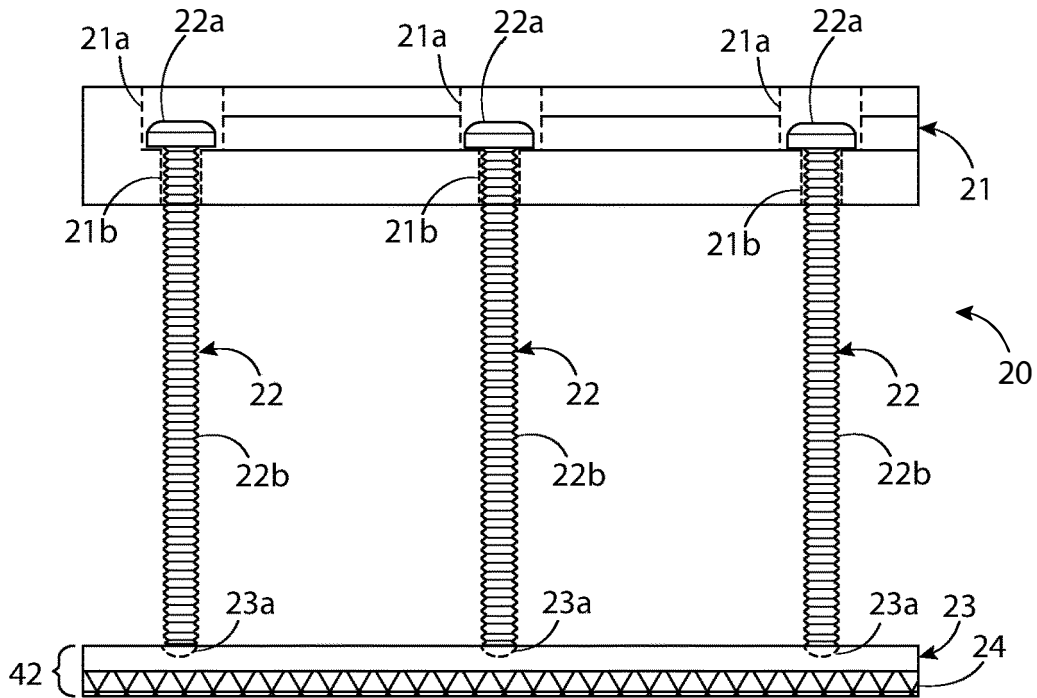

FIG. 32

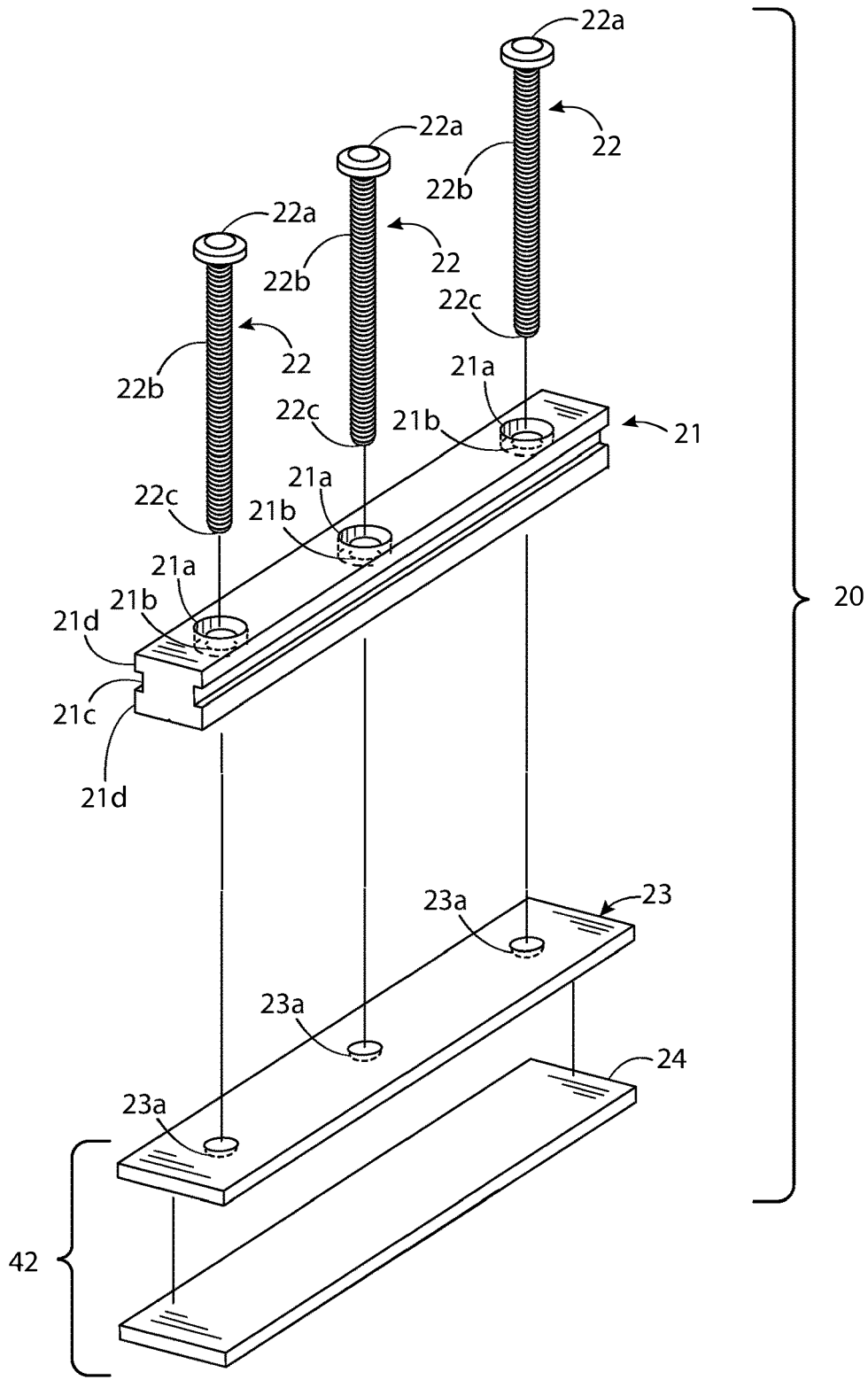

FIG. 33

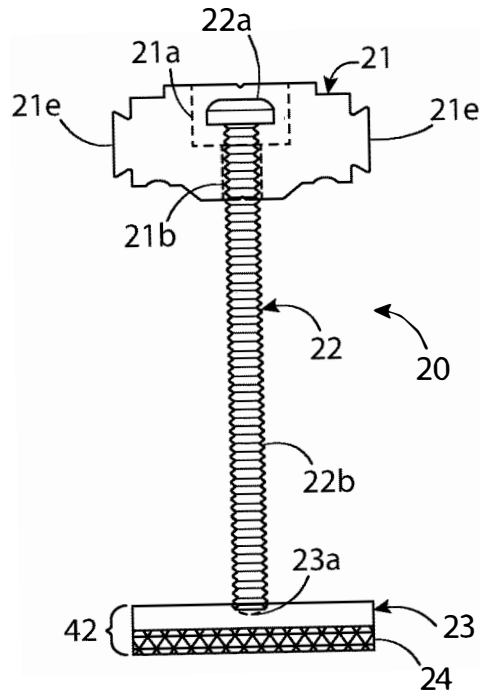

FIG. 34

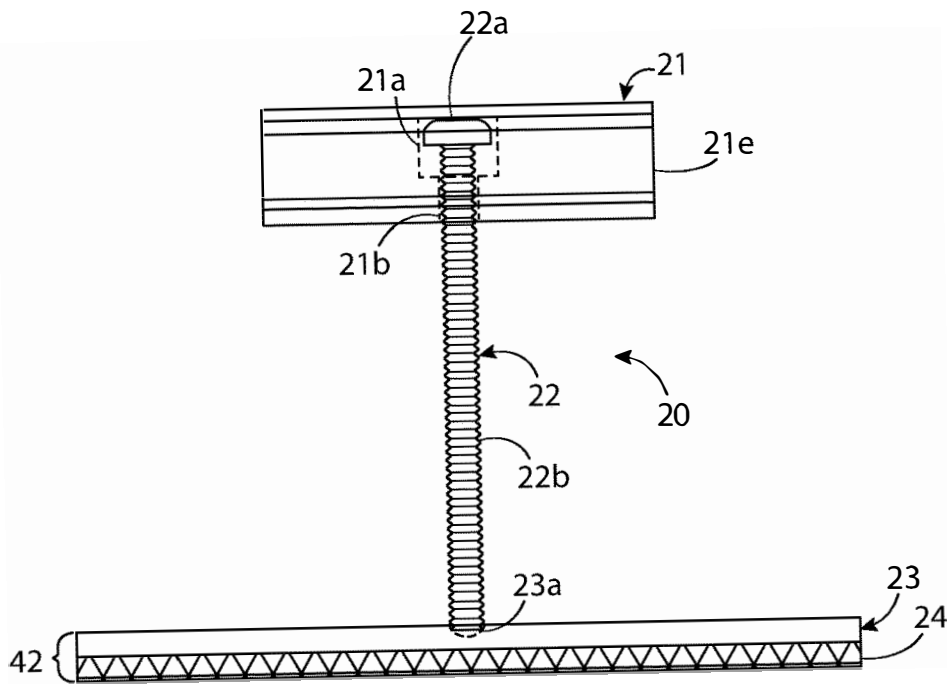

FIG. 35

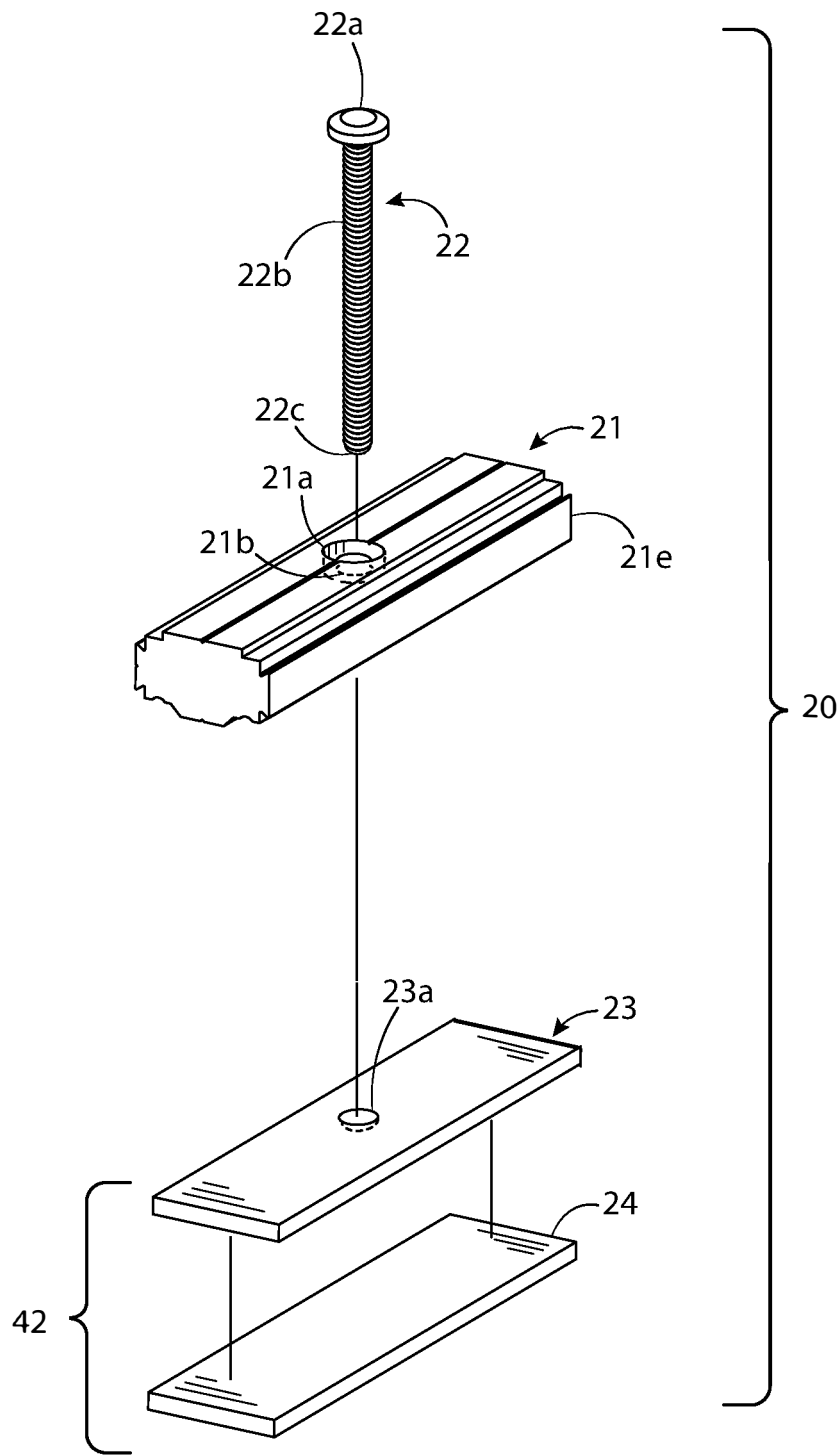

FIG. 36

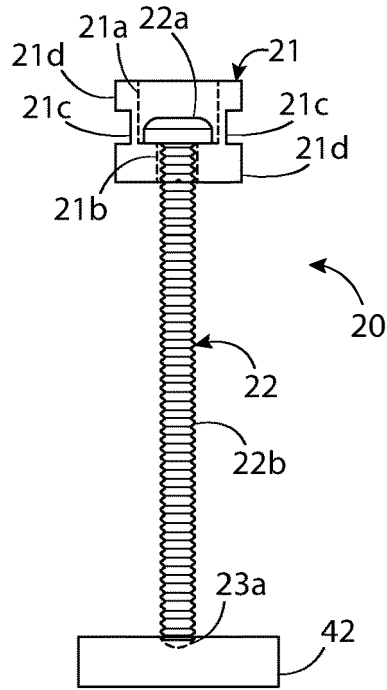

FIG. 37

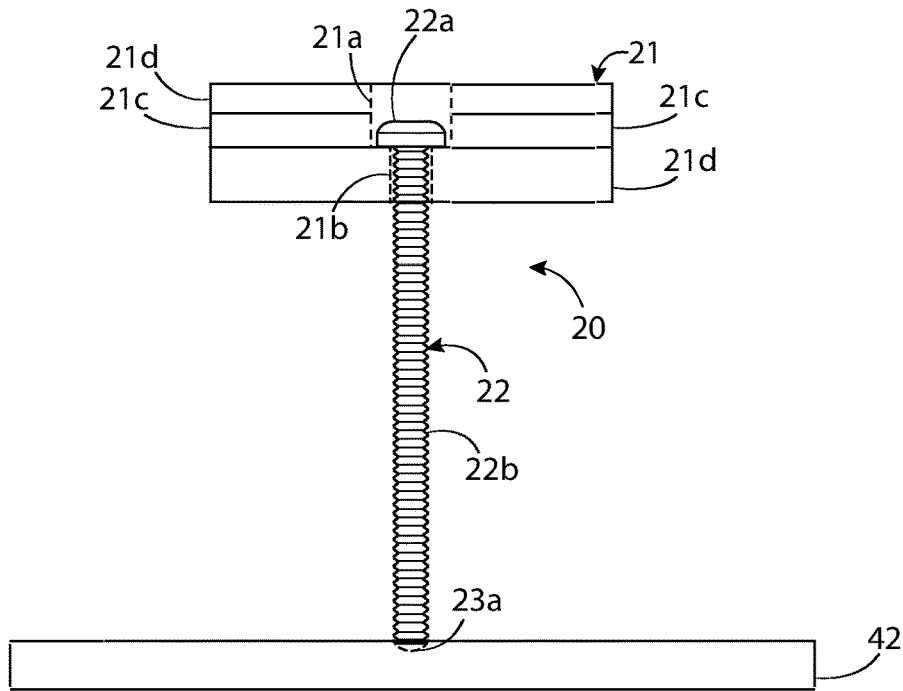

FIG. 38

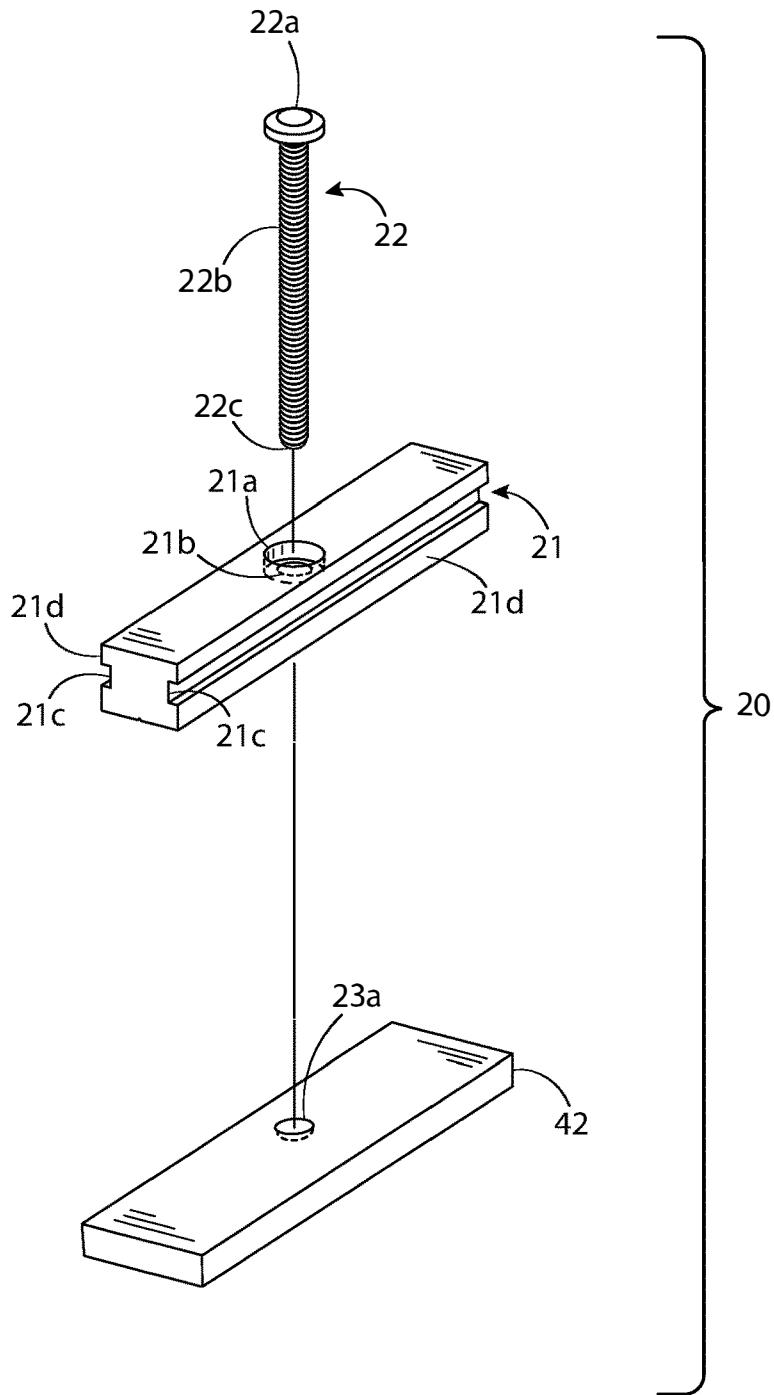

FIG. 39

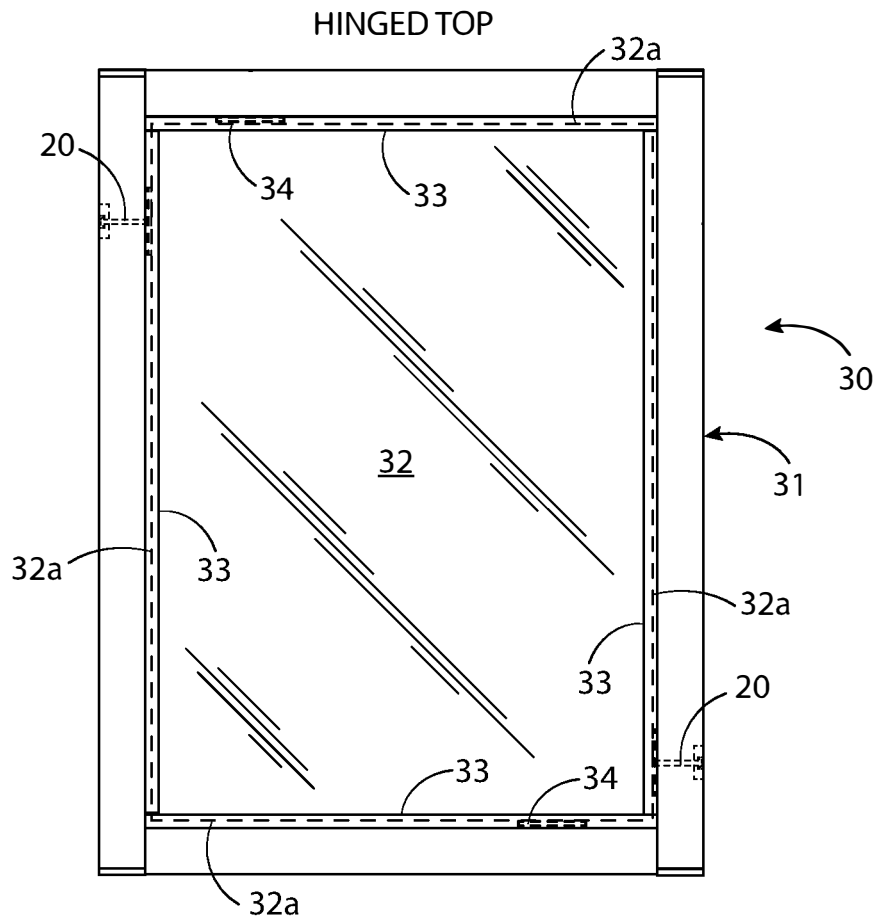

FIG. 40

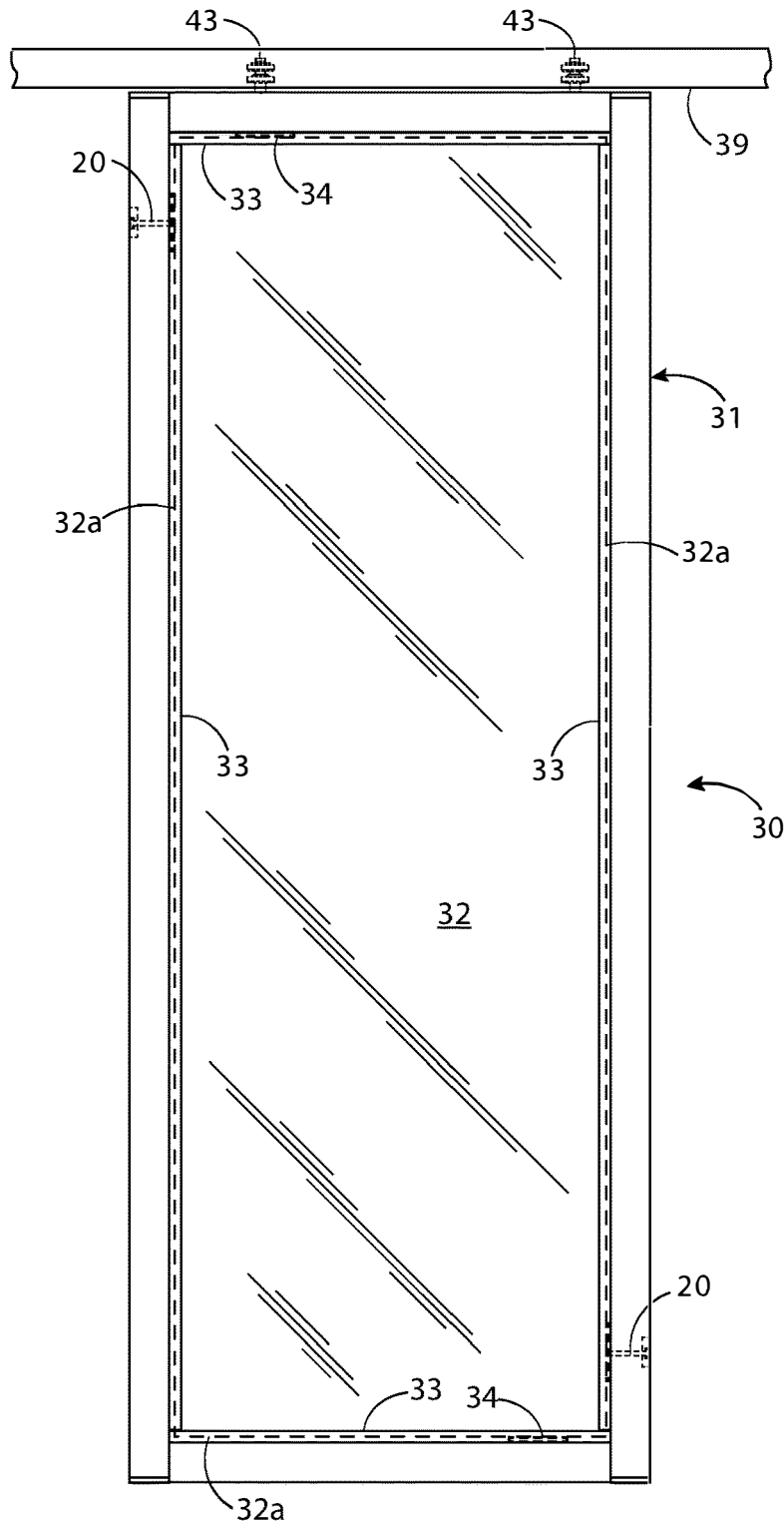

FIG. 41