



(12) **United States Patent**  
**Header et al.**

(10) **Patent No.:** **US 9,598,892 B2**  
(45) **Date of Patent:** **Mar. 21, 2017**

(54) **QUICK RELEASE CLADDING SYSTEM FOR DOOR, WINDOW, SLOPED AND VERTICAL GLAZING SYSTEMS FRAMES, AND THE LIKE**

(71) Applicant: **Gregory Header**, Pine Grove, PA (US)

(72) Inventors: **Gregory Header**, Richland, PA (US);  
**Anton Vassilev**, Lebanon, PA (US)

(73) Assignee: **Gregory Header**, Pine Grove, PA (US)

(\*) Notice: Subject to any disclaimer, the term of this patent is extended or adjusted under 35 U.S.C. 154(b) by 43 days.

(21) Appl. No.: **14/487,067**

(22) Filed: **Sep. 15, 2014**

(65) **Prior Publication Data**

US 2016/0076298 A1 Mar. 17, 2016

(51) **Int. Cl.**  
**E06B 1/34** (2006.01)  
**E06B 3/30** (2006.01)

(52) **U.S. Cl.**  
CPC ..... **E06B 1/34** (2013.01); **E06B 3/303** (2013.01)

(58) **Field of Classification Search**  
CPC ..... E06B 1/04; E06B 1/06; E06B 1/08; E06B 1/34; E06B 1/342; E06B 1/40; E06B 1/60; E06B 1/56; E06B 1/605; E06B 1/6023; E06B 3/9632; E06B 3/964; E06B 3/9647; E06B 3/968; E06B 3/9684; E06B 3/988; E04F 19/02; E04F 19/0459; E04F 19/0468; E04F 19/0472; E04F 19/0481; E04F 19/0495; E04B 2/88; E04B 2/96; E04B 2/965; E04B 2/967

See application file for complete search history.

(56) **References Cited**

U.S. PATENT DOCUMENTS

2,346,264	A *	4/1944	Marshall	.....	E04F 19/0495
					144/353
3,161,926	A *	12/1964	Schaub	.....	E04F 19/0468
					52/241
3,593,473	A *	7/1971	King	.....	E06B 1/16
					52/211
4,586,306	A	5/1986	Webb		
4,621,471	A *	11/1986	Kuhr	.....	E04B 2/82
					52/242
4,694,612	A	9/1987	Pruden et al.		
4,890,435	A	1/1990	Wilkening et al.		
4,967,525	A	11/1990	Koester		

(Continued)

FOREIGN PATENT DOCUMENTS

AU	641250	B2	1/1992
CA	1315603	C	4/1993

(Continued)

*Primary Examiner* — Jessica Laux  
(74) *Attorney, Agent, or Firm* — Stone Creek Services LLC; Alan M Flum

(57) **ABSTRACT**

Disclosed is quick-release removable cladding for interior fenestration frames, such as the interior frames of doors, window, skylights, or curtain walls. The cladding is held flush against the frame by a pair of brackets or alternatively by a bracket attached to frame and a shaped cavity within the cladding. In one aspect, the pair of brackets can be shaped and arranged so that when engaged, a downward force on the cladding causes the cladding to move flush against the frame. In another aspect, the cladding can be held securely in place to the frame by a keeper bar. The keeper bar can be configured to prevent upward movement of the cladding against the frame.

**13 Claims, 22 Drawing Sheets**

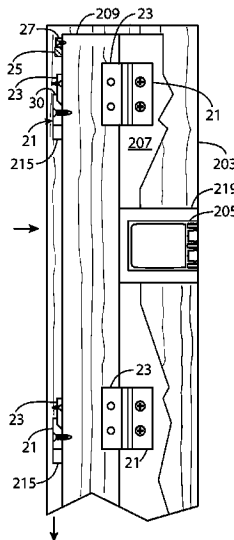

(56)

References Cited

U.S. PATENT DOCUMENTS

4,982,530 A 1/1991 Palmer  
 5,081,793 A 1/1992 Mauro  
 5,224,610 A \* 7/1993 Veazey ..... A47F 5/0846  
 211/162  
 5,481,839 A \* 1/1996 Lang ..... E04B 2/967  
 52/235  
 5,839,236 A \* 11/1998 Frey ..... E04B 2/965  
 52/235  
 6,141,923 A \* 11/2000 Habicht ..... E04B 1/943  
 52/232  
 6,155,010 A 12/2000 Becken et al.  
 6,276,101 B1 \* 8/2001 Schiedegger ..... E06B 1/34  
 52/211  
 6,463,707 B1 \* 10/2002 Schiedegger ..... E04F 19/02  
 52/211  
 6,745,523 B2 6/2004 Petta  
 D621,075 S 8/2010 Haeussler  
 8,359,795 B2 1/2013 Beland  
 8,578,671 B2 \* 11/2013 Labrecque ..... E04B 2/967  
 52/235  
 8,631,619 B2 1/2014 Clayton et al.  
 8,769,901 B2 7/2014 Todd et al.  
 2002/0112423 A1 \* 8/2002 Schiedegger ..... E04F 19/02  
 52/211  
 2003/0145538 A1 \* 8/2003 Kerscher ..... E06B 1/34  
 52/212  
 2006/0207197 A1 \* 9/2006 Anderson ..... E04F 19/024  
 52/211  
 2008/0178541 A1 \* 7/2008 Kerscher ..... E06B 1/34  
 52/204.1  
 2009/0064609 A1 \* 3/2009 Ouyang ..... E06B 1/34  
 52/211  
 2012/0233944 A1 \* 9/2012 Reifer ..... E04B 2/965  
 52/235  
 2012/0241574 A1 9/2012 Uota et al.  
 2012/0272605 A1 \* 11/2012 Huang ..... E04B 2/96  
 52/483.1

2012/0291391 A1 11/2012 McDonald  
 2013/0180189 A1 \* 7/2013 Reifer ..... E04B 2/967  
 52/204.593  
 2013/0312352 A1 11/2013 Gale  
 2013/0333321 A1 \* 12/2013 Dollerup ..... E04B 2/7457  
 52/696  
 2014/0215939 A1 \* 8/2014 Gosling ..... E06B 1/34  
 52/211  
 2015/0197979 A1 \* 7/2015 Hawk ..... E06B 3/9645  
 52/656.5  
 2015/0284951 A1 \* 10/2015 Frederick ..... E04B 2/965  
 52/235

FOREIGN PATENT DOCUMENTS

CA 2643557 C 5/2009  
 CH 659679 A5 4/1986  
 CN 202755618 U 2/2013  
 CN 202755811 U 2/2013  
 CN 203034715 U 7/2013  
 CN 103470142 A 12/2013  
 CN 203613950 U 5/2014  
 CN 203613980 U 5/2014  
 DE 19748418 A1 5/1999  
 DE 10029744 A1 4/2001  
 DE 102012110546 A1 5/2014  
 EP 53104 A 6/1982  
 EP 517057 A2 12/1992  
 EP 987396 A2 3/2000  
 EP 1091075 A1 4/2001  
 EP 1338746 A2 8/2003  
 FR 2440459 A1 5/1980  
 FR 2910509 A1 6/2008  
 GB 1054925 A 1/1967  
 GB 2251645 A 7/1992  
 GB 2233682 B 11/1993  
 GB 2468161 A 9/2010  
 KR 100740254 B1 7/2007  
 WO 2010001544 C2 2/2010

\* cited by examiner

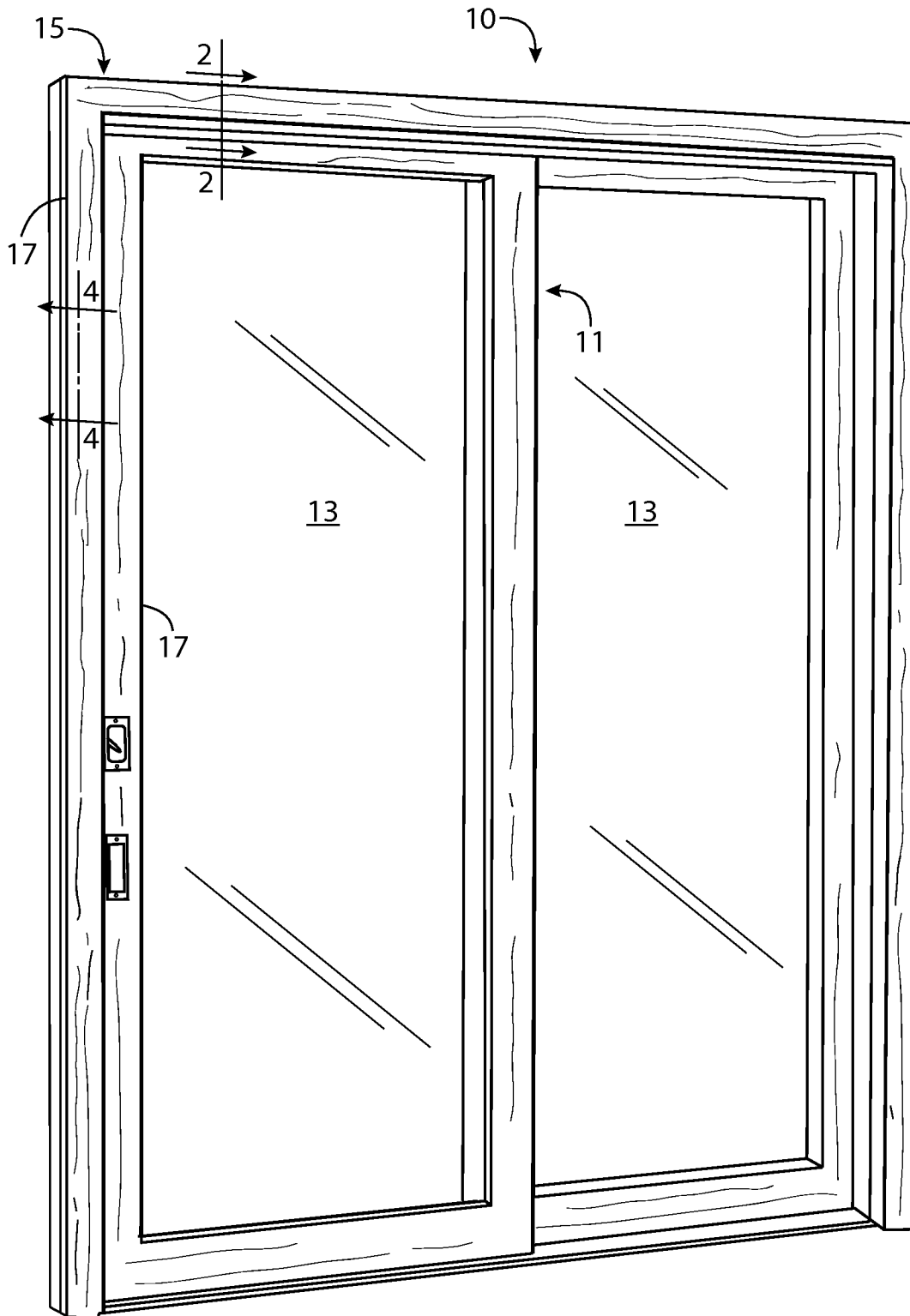

FIG.1

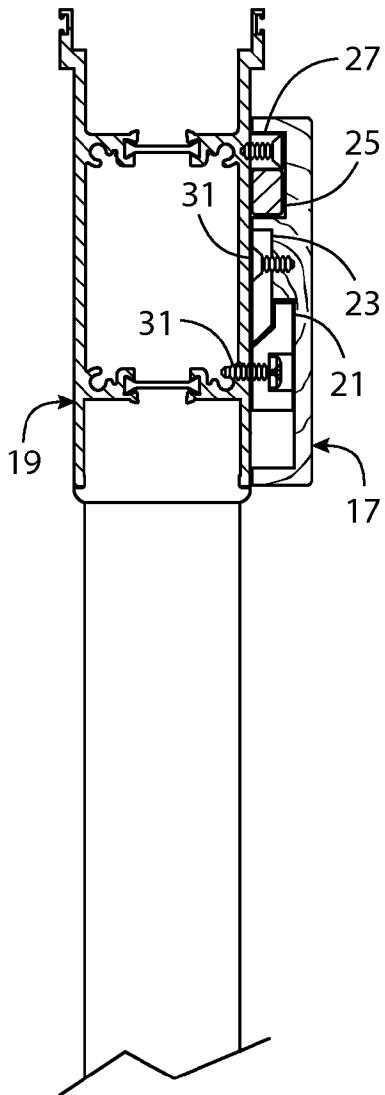

FIG. 2

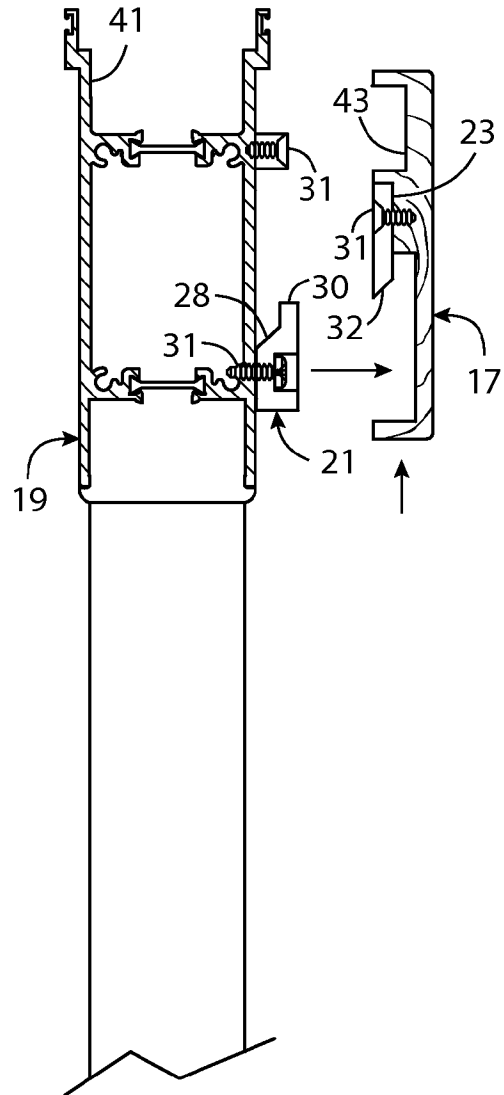

FIG. 3

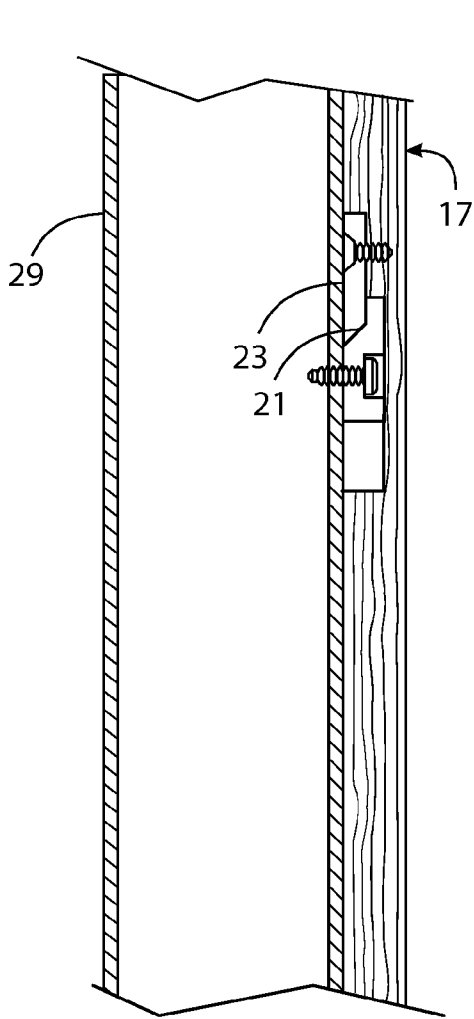

FIG. 4

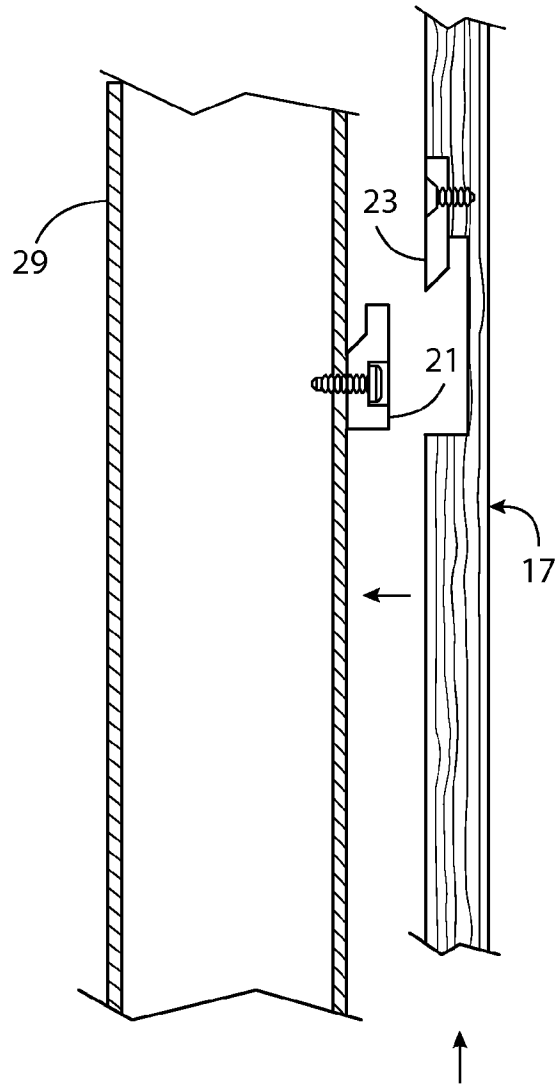

FIG. 5

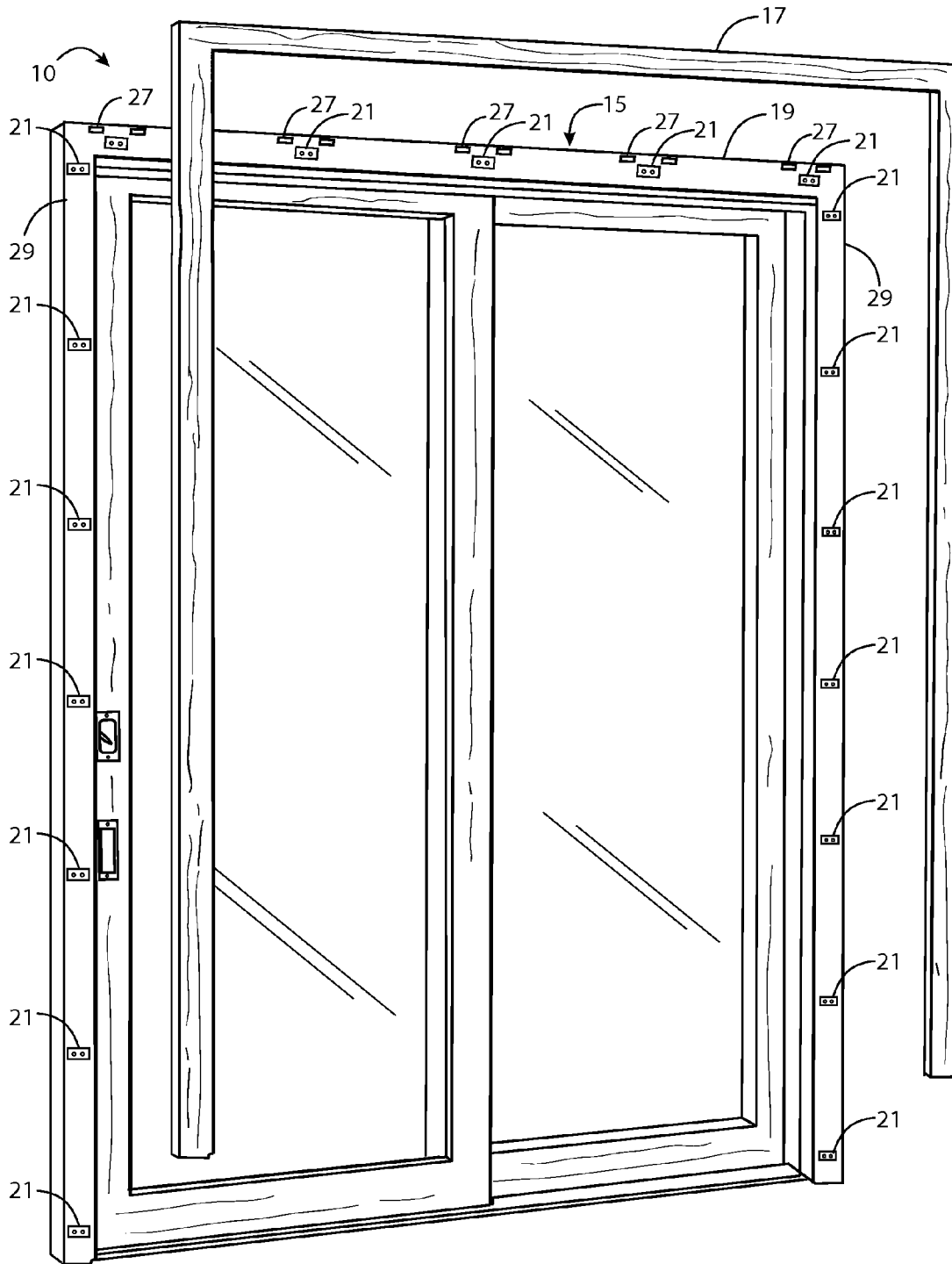

FIG. 6

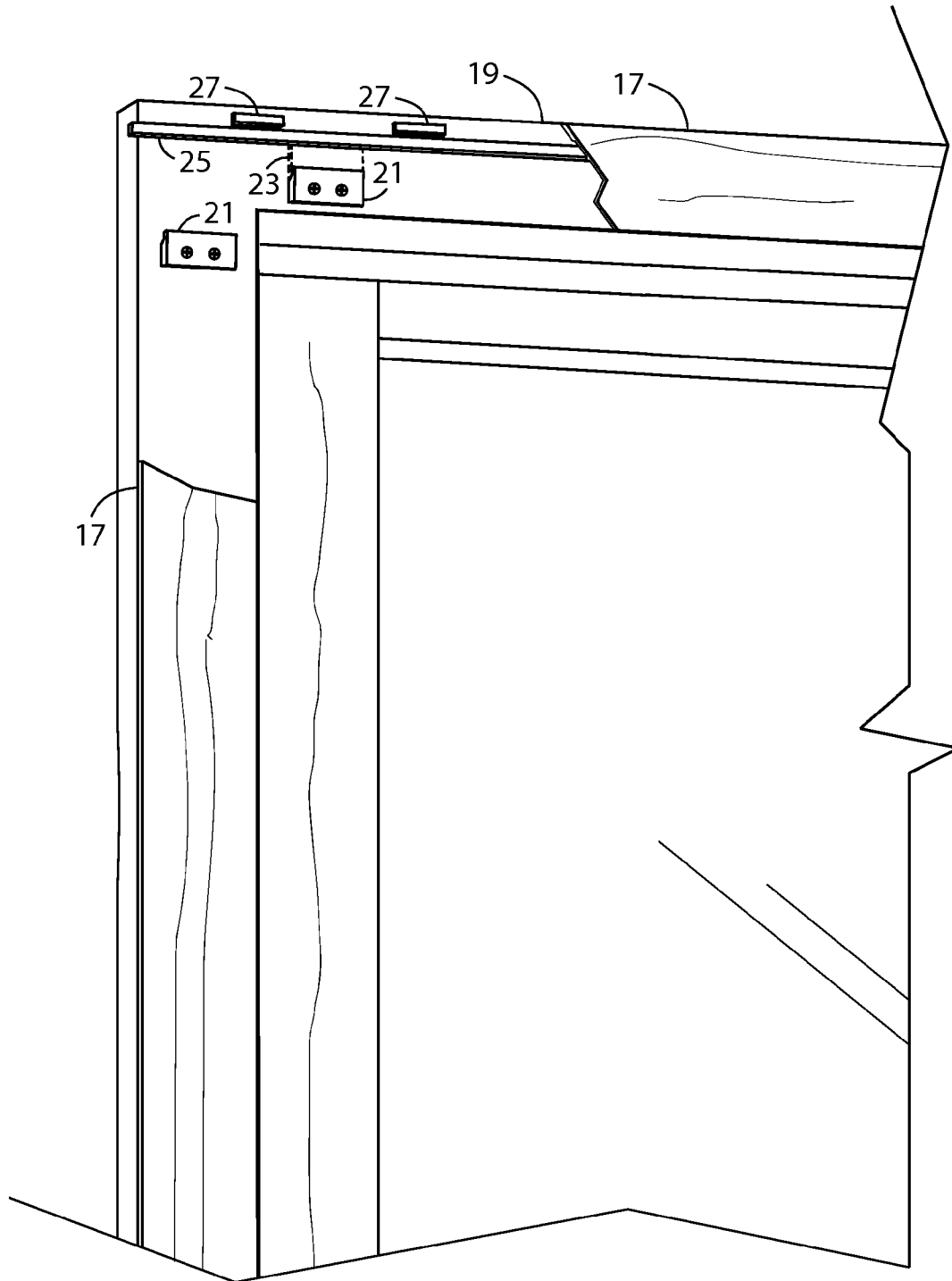

FIG. 7

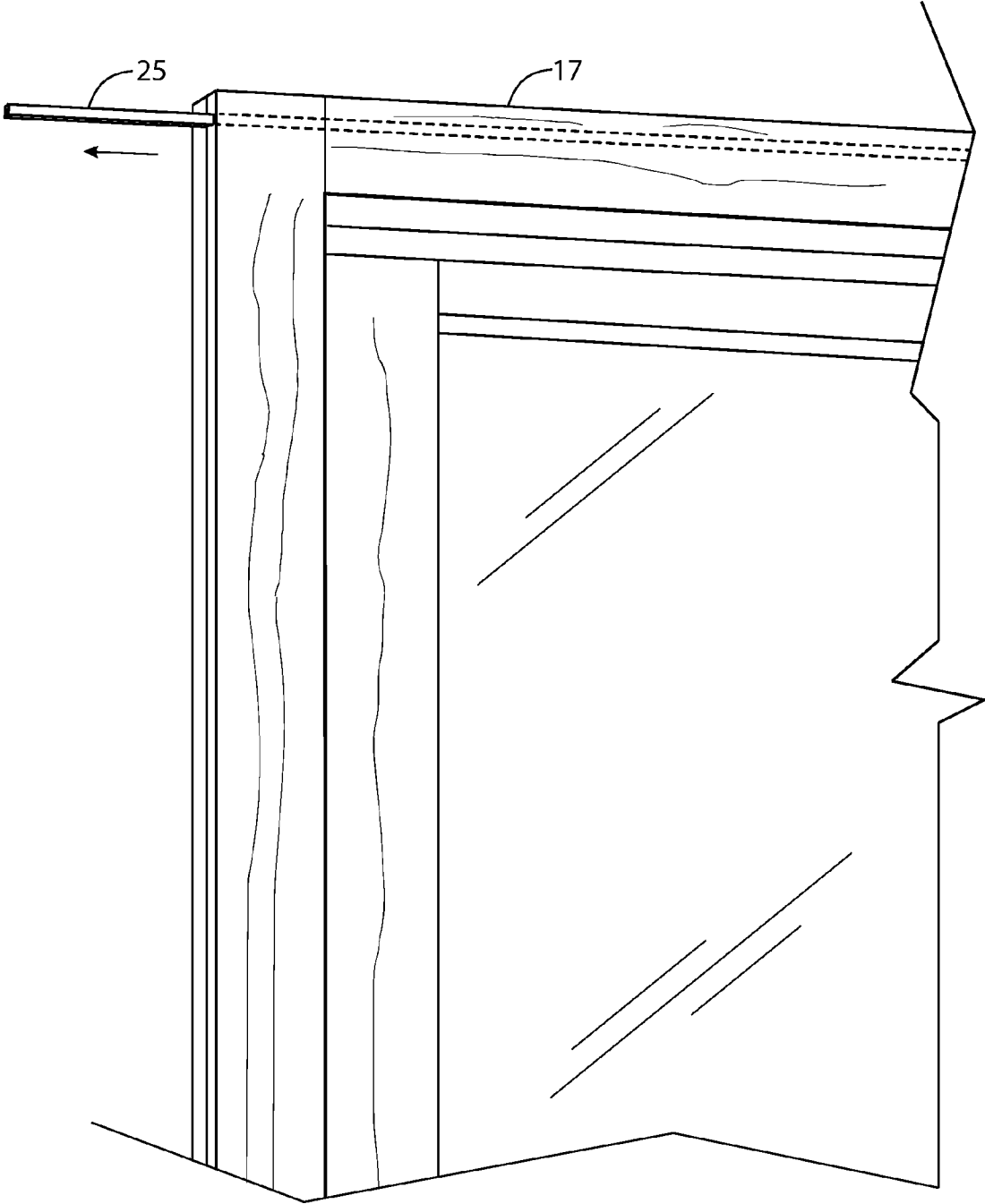

FIG. 8



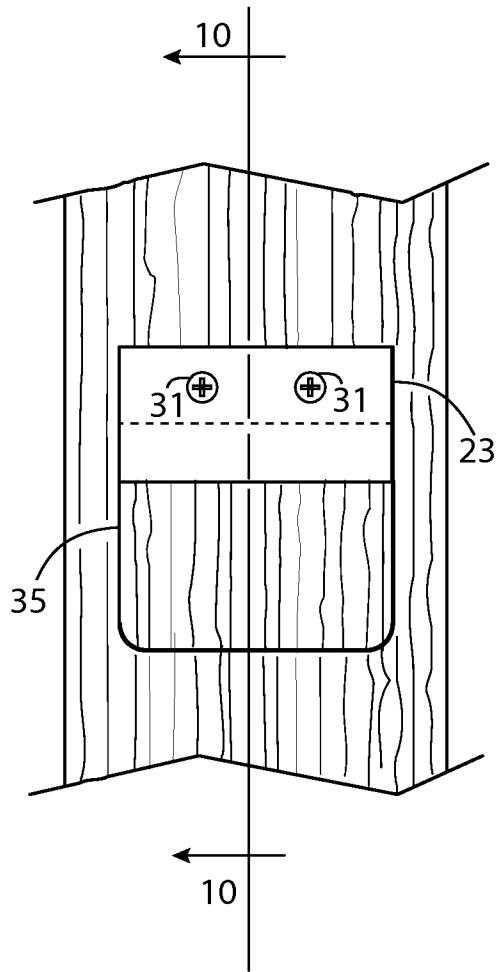

FIG. 9

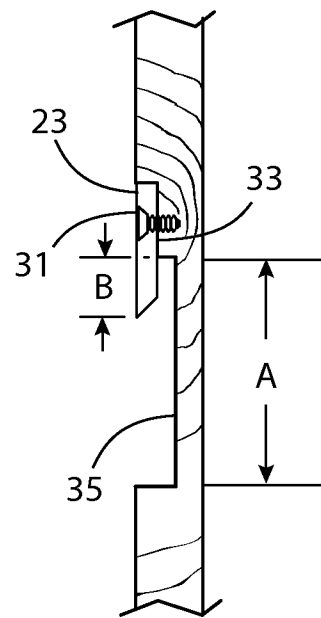

FIG. 10

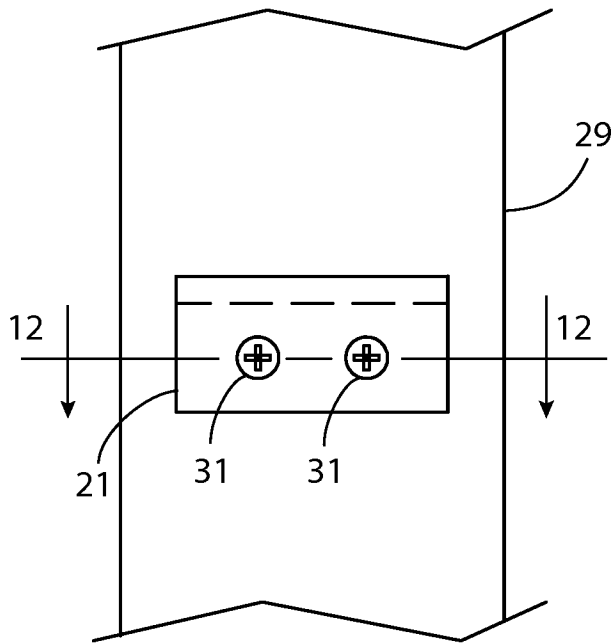

FIG. 11

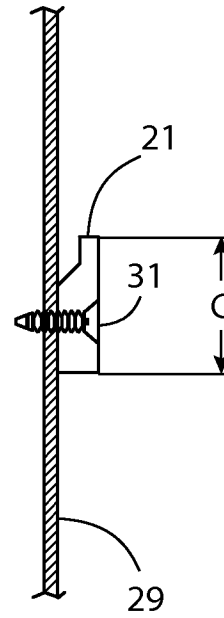

FIG. 13

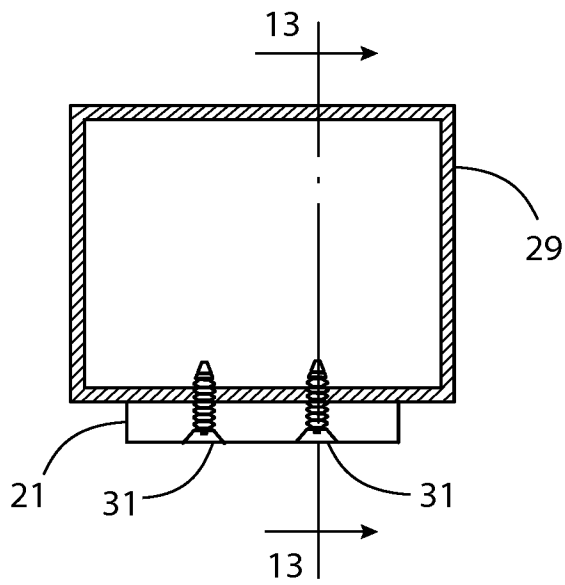

FIG. 12

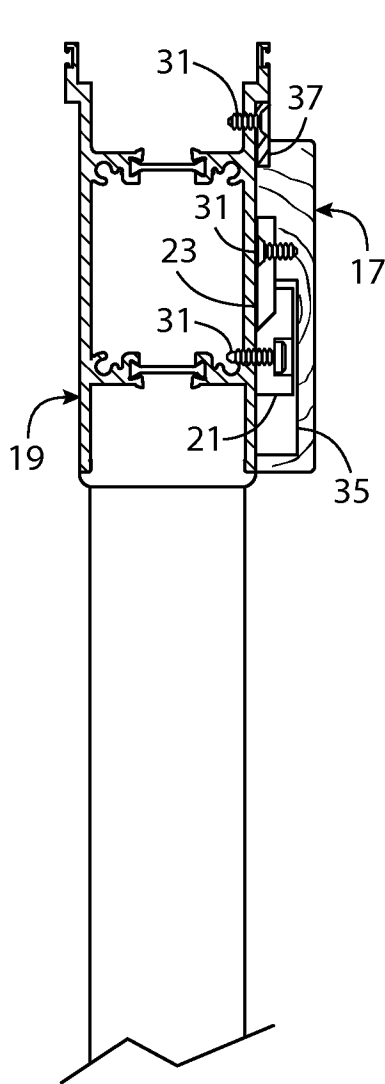

FIG. 14

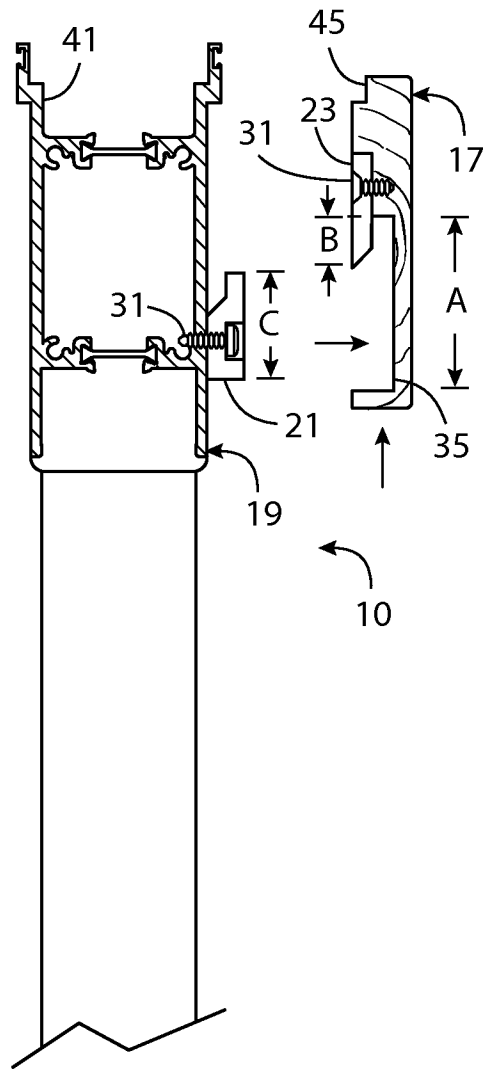

FIG. 15

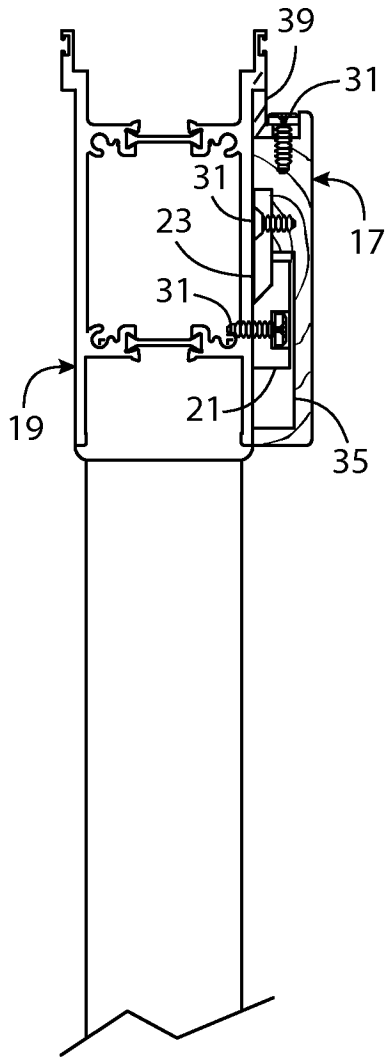

FIG. 16

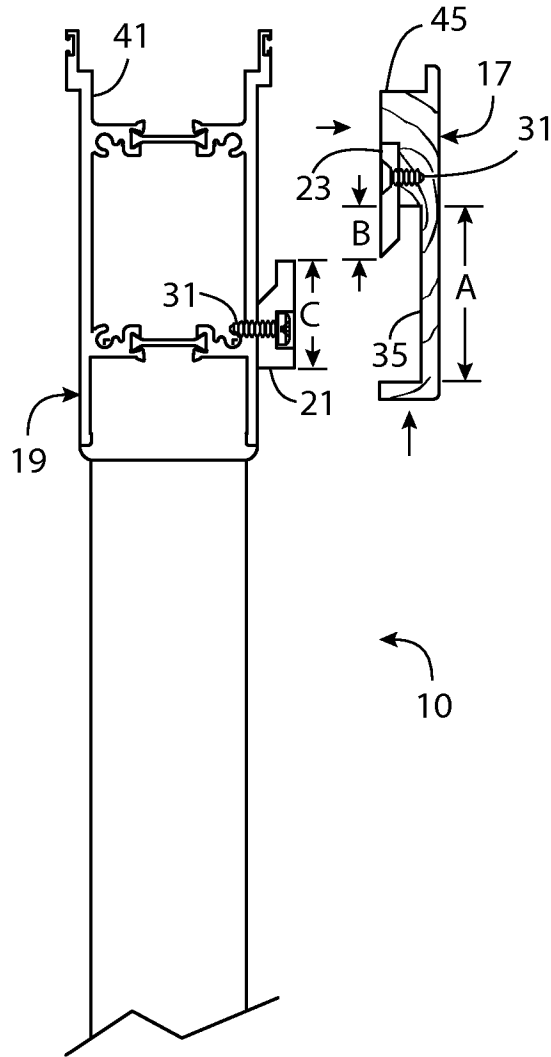

FIG. 17

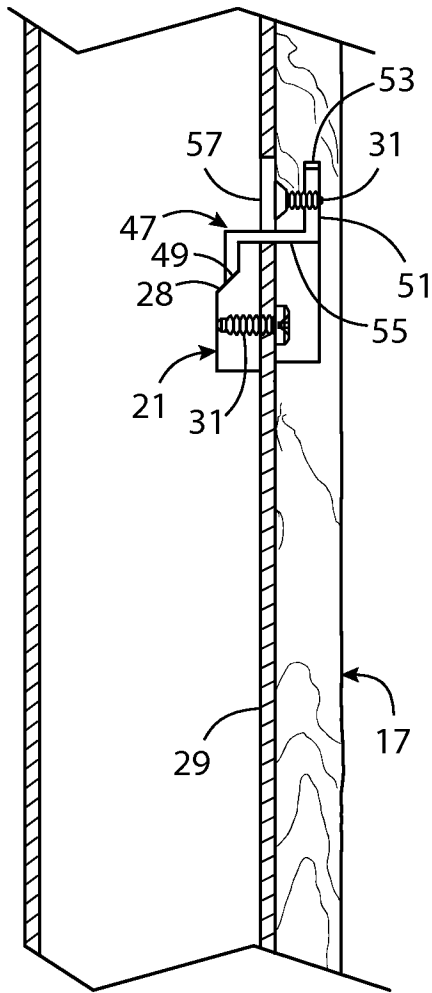

FIG. 18

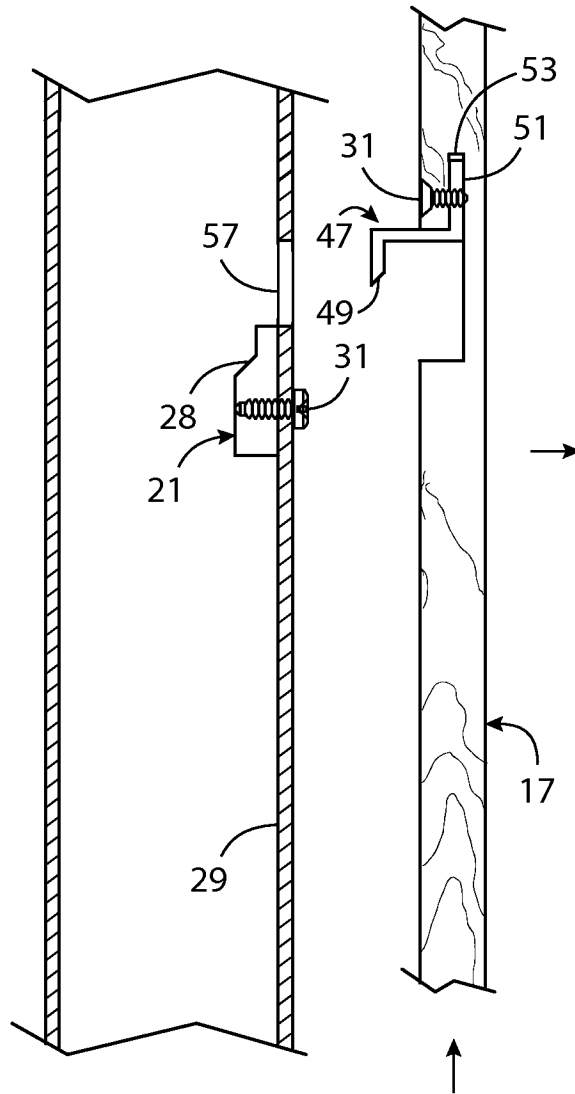

FIG. 19

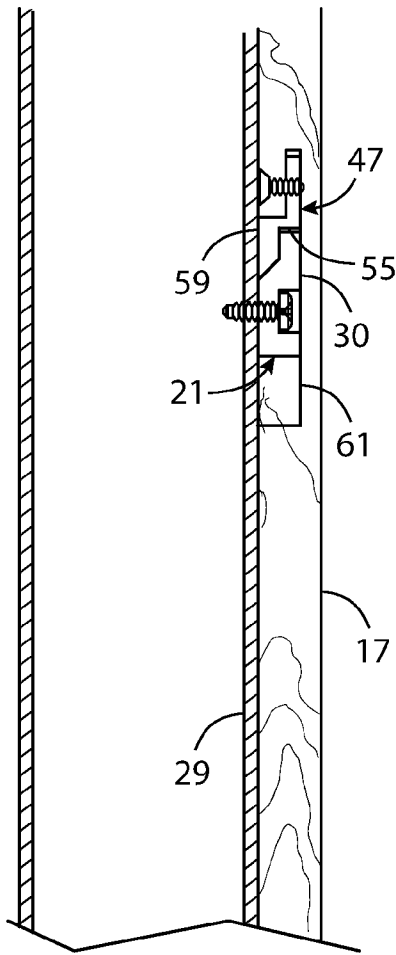

FIG. 20

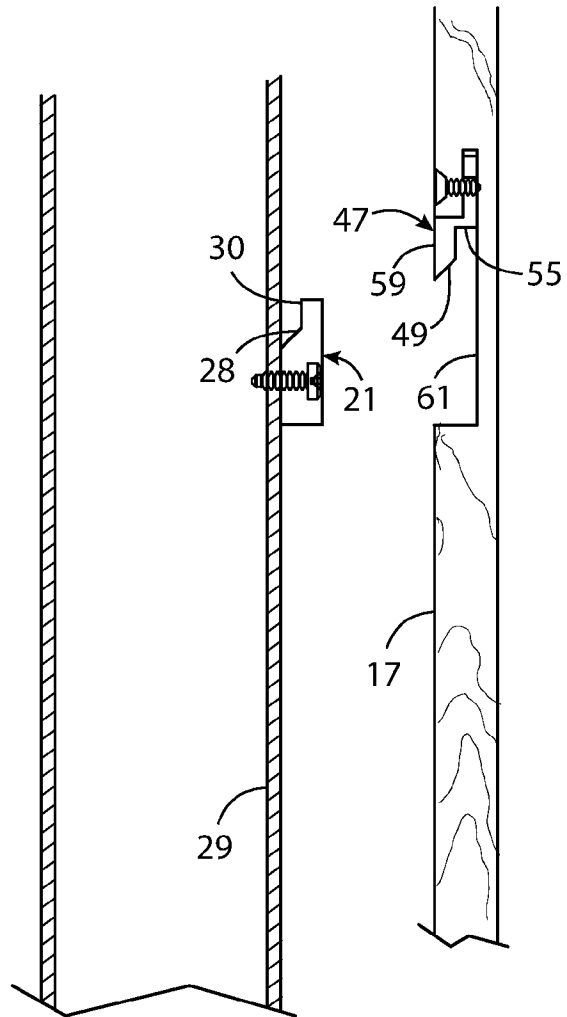

FIG. 21

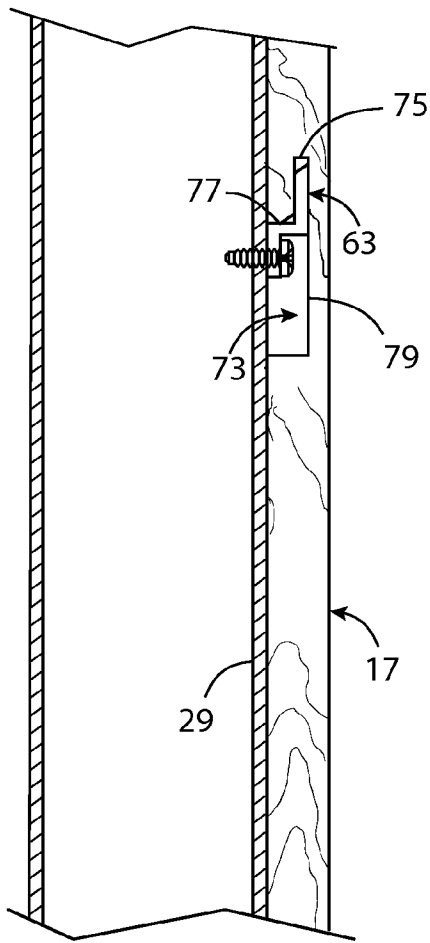

FIG. 22

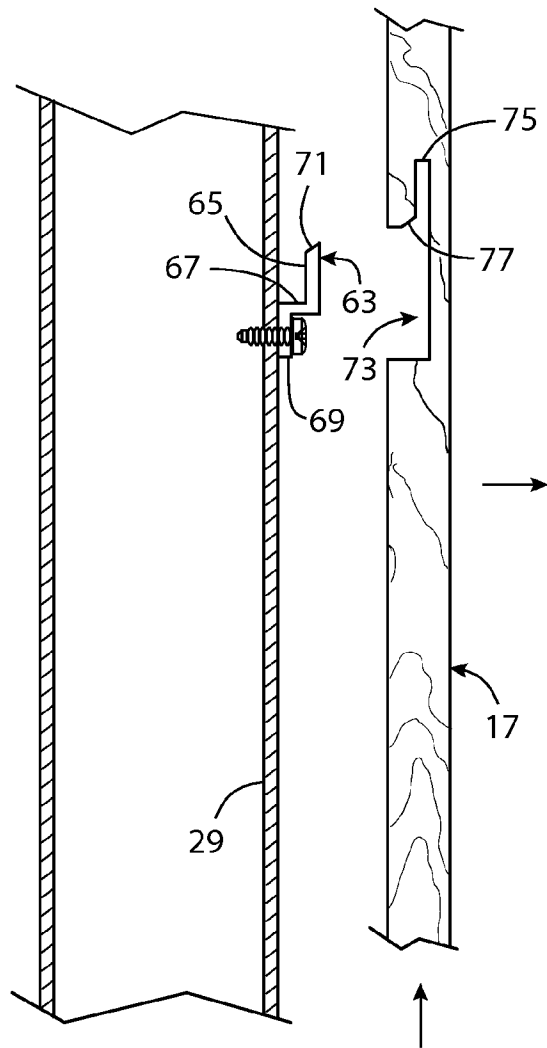

FIG. 23

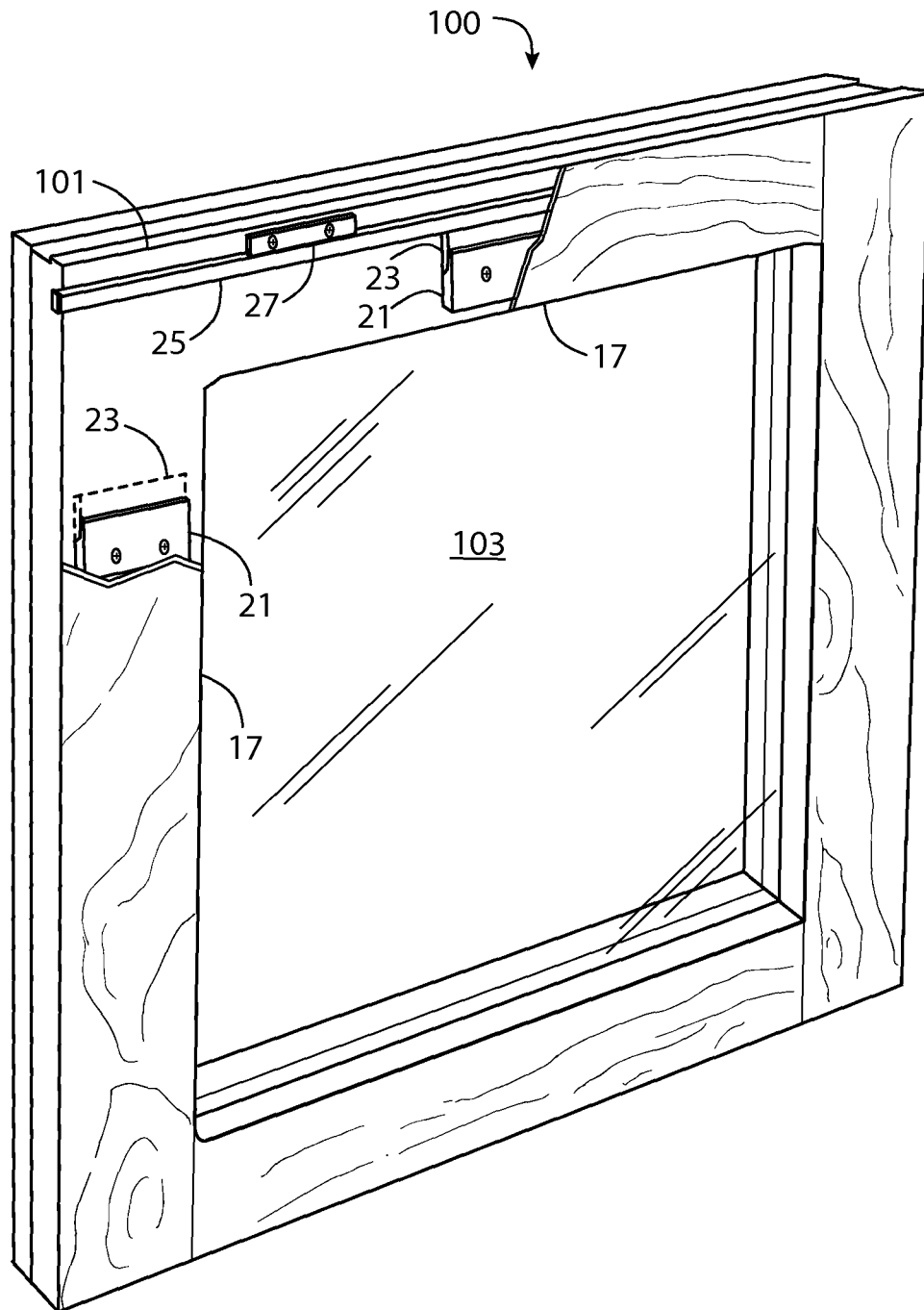

FIG. 24



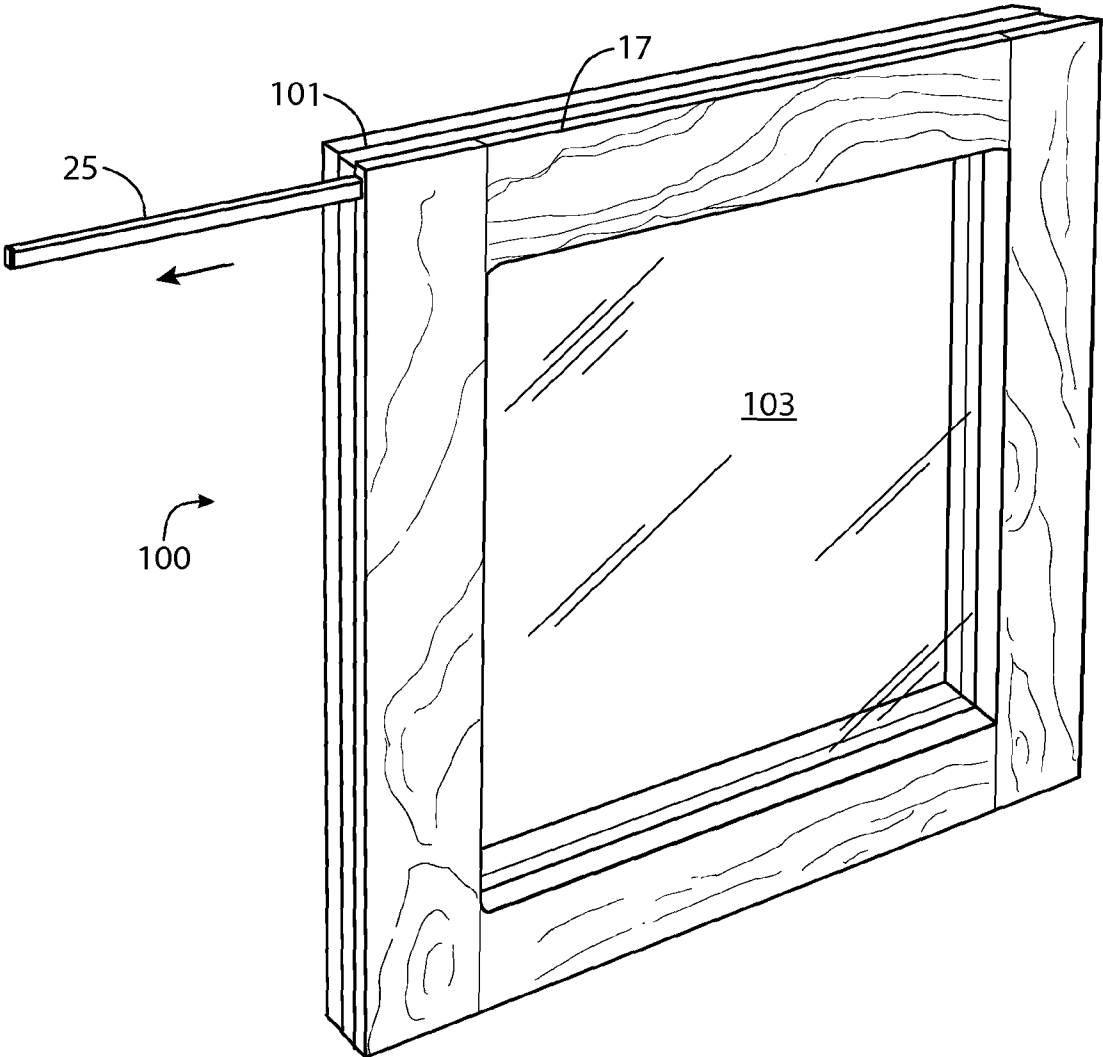

FIG. 25

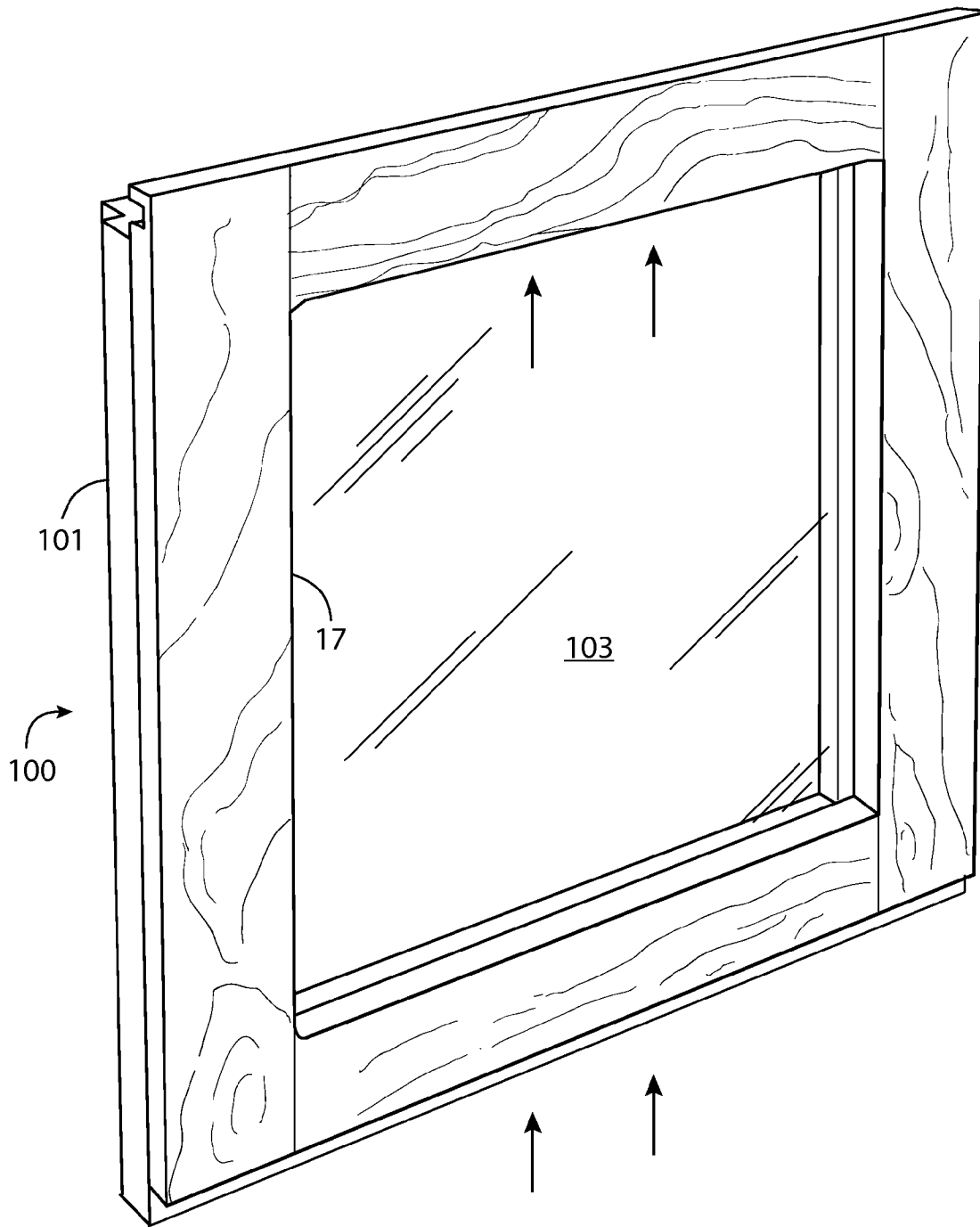

FIG. 26

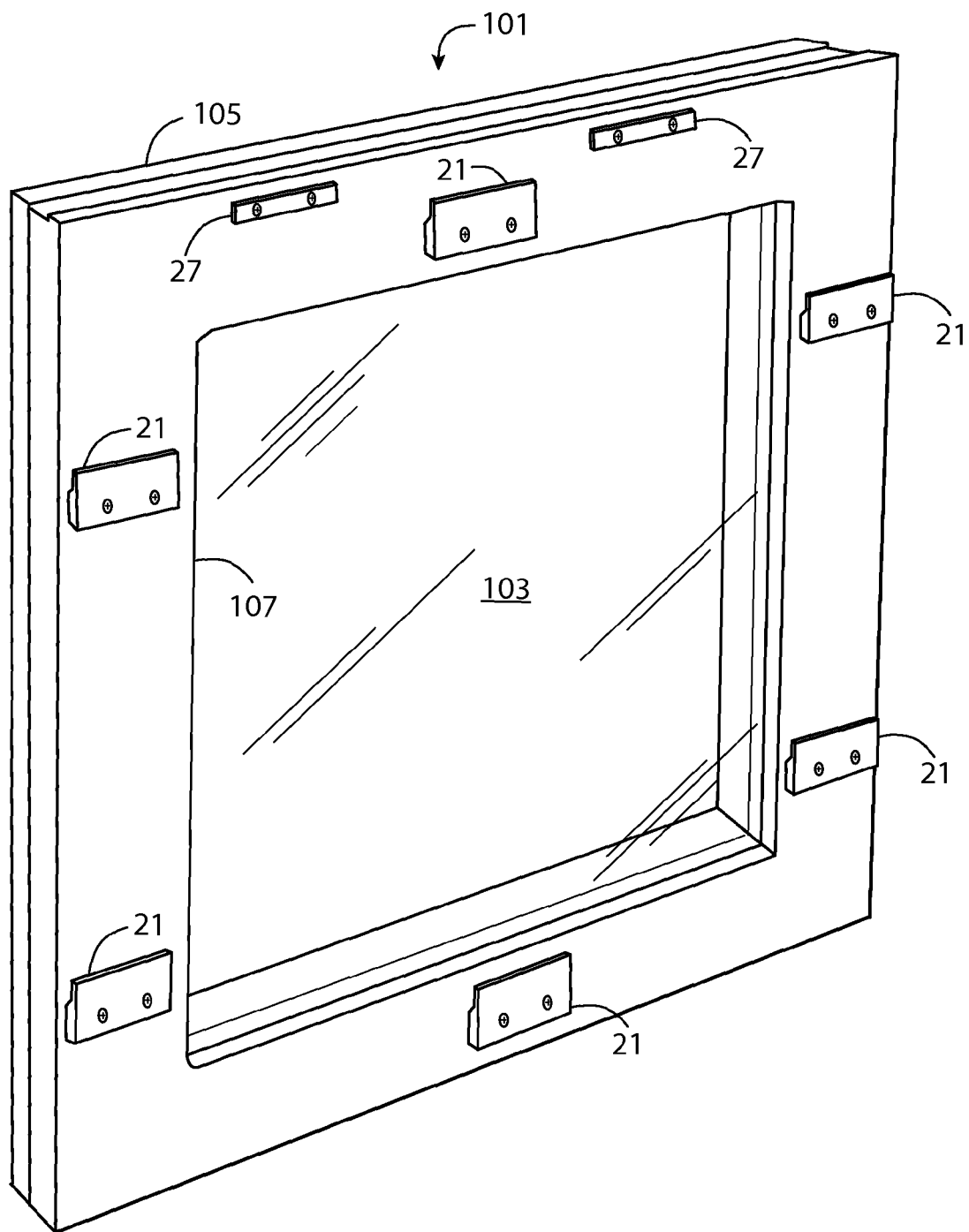

FIG. 27

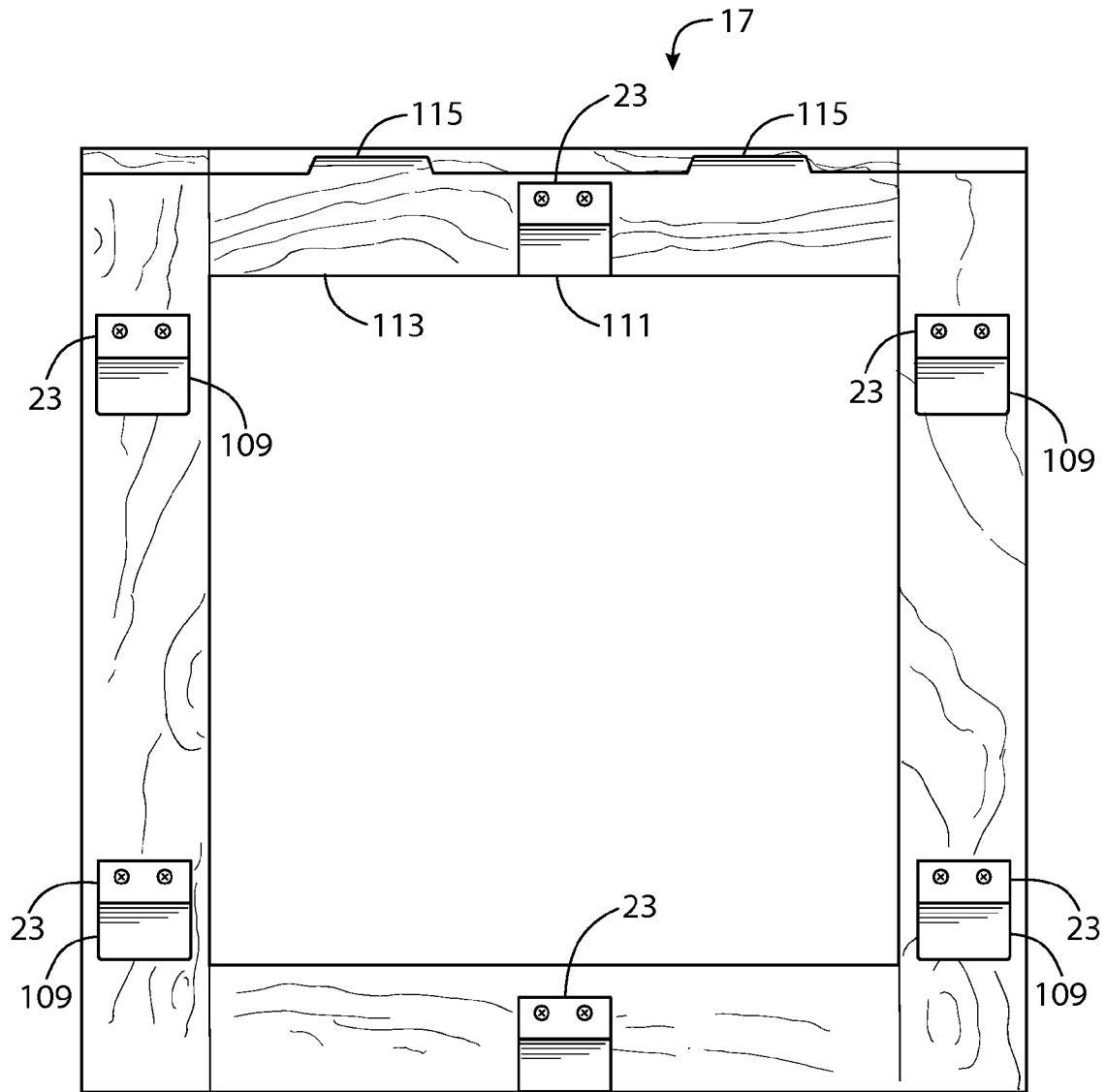

FIG. 28

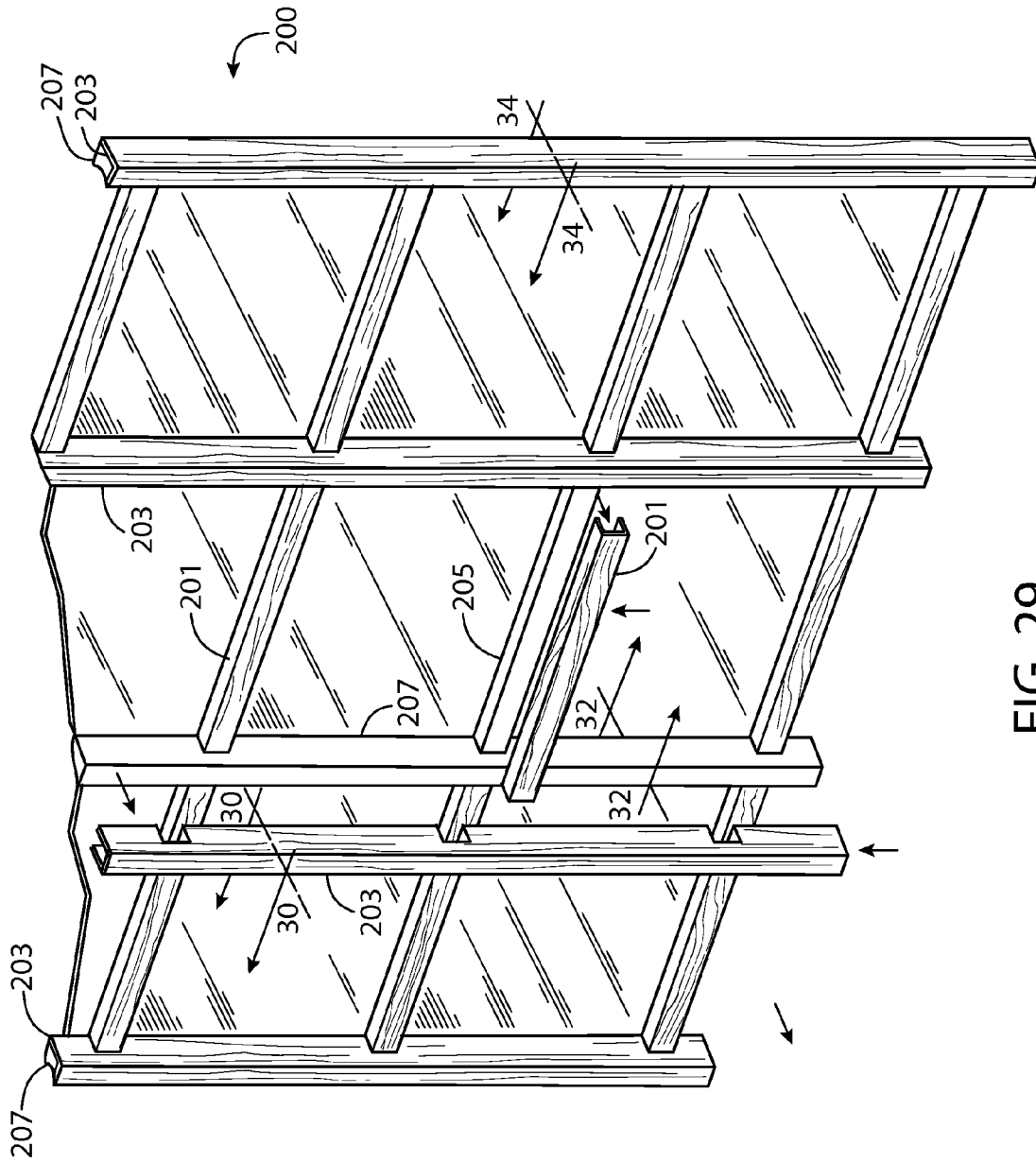

FIG. 29

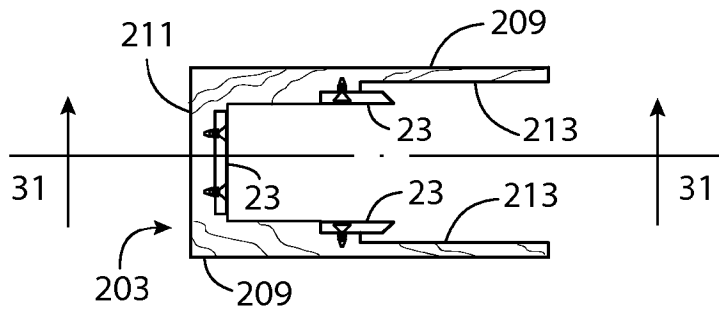

FIG. 30

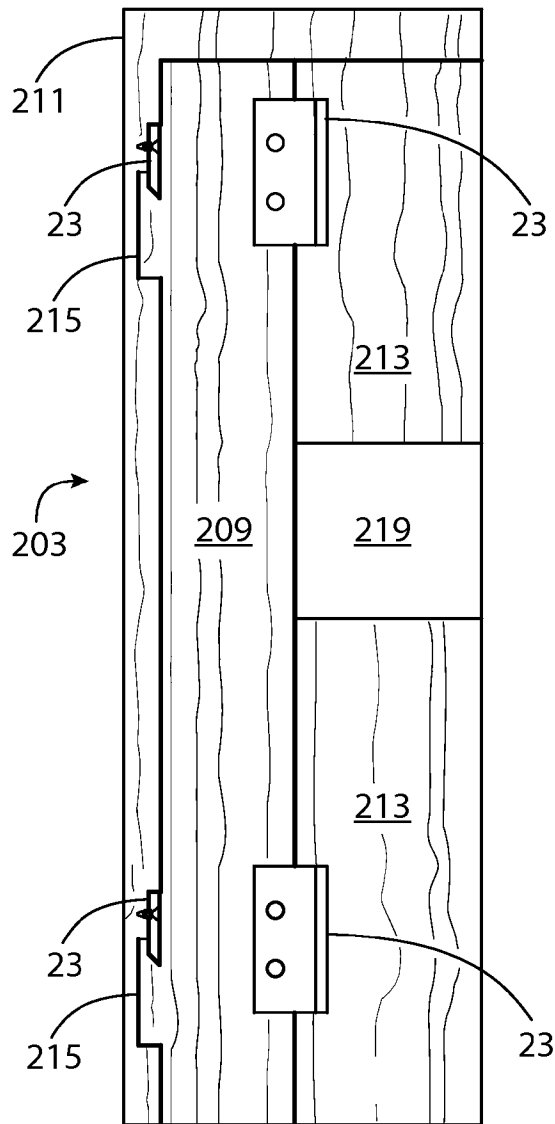

FIG. 31

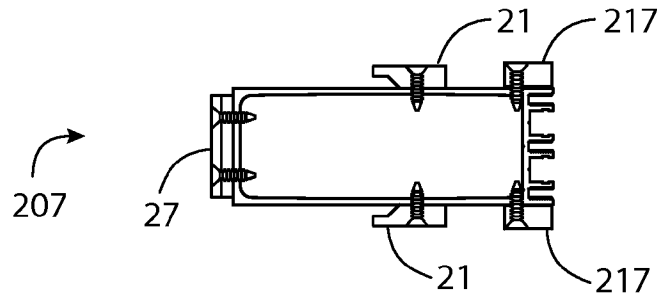

FIG. 32

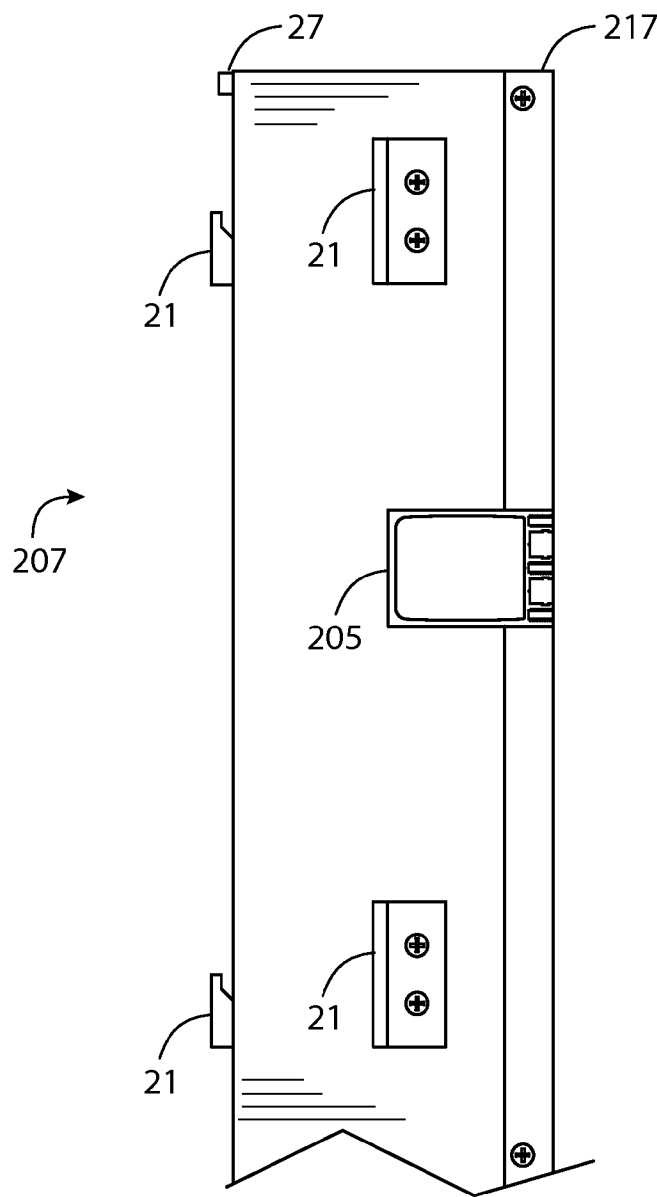

FIG. 33

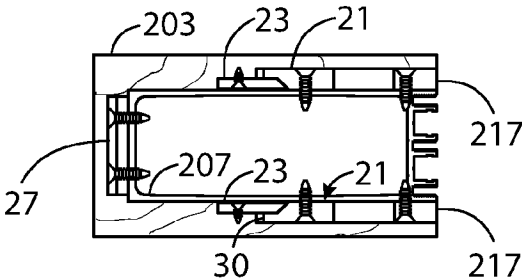

FIG. 34

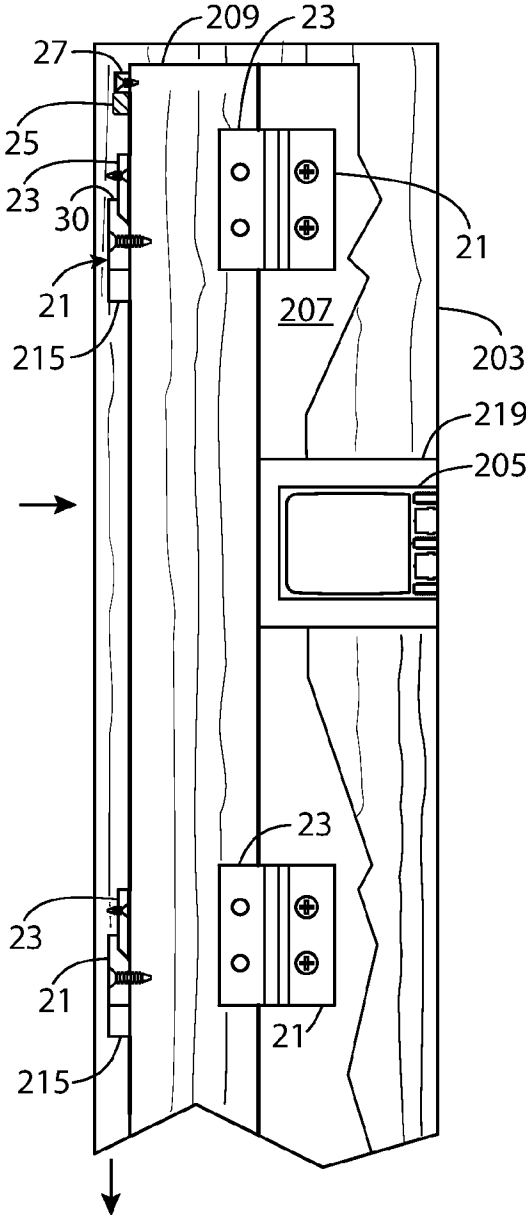

FIG. 35