



(12) **United States Patent Header**

(10) **Patent No.:** US 9,725,936 B2
(45) **Date of Patent:** Aug. 8, 2017

(54) **DOOR CATCH**

(56) **References Cited**

(71) Applicant: **Gregory Header**, Richland, PA (US)

U.S. PATENT DOCUMENTS

(72) Inventor: **Gregory Header**, Richland, PA (US)

41,451 A 2/1864 Streeter
389,110 A 9/1888 Roselius
392,133 A 10/1888 Peck
945,461 A 1/1910 Hubbard

(Continued)

(*) Notice: Subject to any disclaimer, the term of this patent is extended or adjusted under 35 U.S.C. 154(b) by 40 days.

FOREIGN PATENT DOCUMENTS

(21) Appl. No.: **14/957,605**

CH 104523 A 5/1924
CH 244295 A 9/1946

(Continued)

(22) Filed: **Dec. 3, 2015**

OTHER PUBLICATIONS

(65) **Prior Publication Data**
US 2016/0083985 A1 Mar. 24, 2016

Roller and Ball Catches, accessed on the Internet at: <http://www.baldwinhardware.com/products/categories/Accessories/Door-Accessories/Roller-Ball-Catches.aspx> on Jul. 22, 2013.

(Continued)

Related U.S. Application Data

Primary Examiner — Alyson M Merlino
(74) *Attorney, Agent, or Firm* — Stone Creek Services LLC; Alan M Flum

(62) Division of application No. 13/960,308, filed on Aug. 6, 2013, now Pat. No. 9,228,387.

(57) **ABSTRACT**

(51) **Int. Cl.**
E05C 19/00 (2006.01)
E05C 19/04 (2006.01)
E05F 5/02 (2006.01)
E05C 17/46 (2006.01)
E05C 17/52 (2006.01)
E05B 15/02 (2006.01)

Disclosed is a door catch that can help to prevent door sag, especially for heavy or tall residential or commercial doors, and provides for post-installation catch tension adjustment without removal or adjustment of mounting members. In one aspect, the door catch can include a ball catch base, a threaded ball plunger assembly, a catch bumper, and a bumper base. In another aspect, the catch bumper and the bumper base can optionally be combined into a single catch bar bracket. The ball plunger assembly is adjustably mounted within a threaded aperture of ball catch base. A ball captive in one end of the ball plunger assembly engages a detent in the catch bumper, or catch bar bracket, providing friction to hold the door open. The position of the ball plunger assembly can be adjusted vertically to increase or decrease the tension between the detent and the ball plunger assembly.

(52) **U.S. Cl.**
CPC *E05C 19/04* (2013.01); *E05C 17/46* (2013.01); *E05C 17/52* (2013.01); *E05F 5/02* (2013.01); *Y10T 16/61* (2015.01)

(58) **Field of Classification Search**
CPC Y10S 292/60; E05F 5/02
USPC 292/DIG. 60
See application file for complete search history.

2 Claims, 17 Drawing Sheets

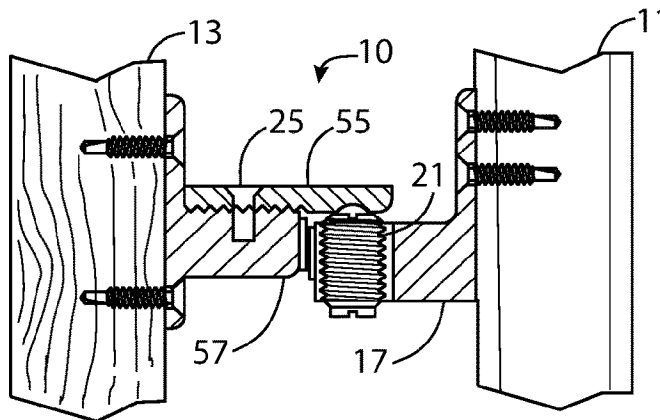

(56)

References Cited

U.S. PATENT DOCUMENTS

1,089,891 A 3/1914 Woolley
 1,100,249 A 6/1914 Newsam
 1,102,207 A 6/1914 Belknap
 1,069,932 A 8/1914 Dupart
 1,330,945 A 2/1920 Kuhn
 1,356,685 A 10/1920 Allmand
 1,383,582 A 7/1921 Stubbs
 1,449,477 A 3/1923 Wiley
 1,501,584 A * 7/1924 Cox E05D 13/06
 292/73
 1,514,845 A 11/1924 Fischer
 1,686,805 A 10/1928 Forg
 1,692,366 A 11/1928 Bean
 1,914,542 A 6/1933 Teich
 1,941,576 A 1/1934 Pond
 1,969,749 A 8/1934 Harsh
 2,043,550 A * 6/1936 Mumbrauer E05C 19/04
 292/75
 2,087,001 A 7/1937 Johnson
 2,108,326 A 2/1938 Adams
 2,439,057 A 4/1948 Russell
 2,496,691 A 2/1950 Berry
 2,503,076 A 4/1950 Smith
 2,518,992 A 8/1950 Kubatzky
 2,519,011 A 8/1950 Aurandt
 2,526,539 A 10/1950 Carrol
 2,809,061 A 11/1953 Beyer
 2,885,237 A 5/1959 Heyer
 2,990,207 A 6/1961 Heyer
 3,126,221 A 3/1964 Grossman
 3,129,024 A 4/1964 Schuessler
 3,297,347 A 1/1967 Rogers
 3,780,904 A 12/1973 Stanford
 3,966,245 A 6/1976 Losenno
 4,286,352 A 9/1981 Pittasch
 4,772,054 A 9/1988 Schreiber
 4,951,984 A 8/1990 Huang
 6,312,026 B1 11/2001 Workman
 6,370,732 B1 4/2002 Yezersky et al.
 6,513,193 B1 2/2003 Yezersky et al.
 6,629,335 B1 10/2003 Derman

D509,130 S 9/2005 Amy
 6,942,256 B2 9/2005 Amy
 6,971,687 B2 12/2005 Amy
 7,111,360 B1 9/2006 Hsu
 7,226,091 B2 6/2007 Amy
 7,694,461 B2 4/2010 Marocco
 8,327,505 B2 12/2012 Smith
 2007/0040390 A1 2/2007 Pilja
 2007/0069526 A1 3/2007 Hsu
 2011/0119865 A1 5/2011 Vigeh et al.
 2012/0266542 A1 10/2012 Graham

FOREIGN PATENT DOCUMENTS

CN 200810123449 A 6/2008
 CN 201193034 Y 2/2009
 CN 200920211413 U 10/2009
 CN 201521180 Y 7/2010
 EP 1983440047 A 9/1983
 EP 1993201336 A 5/1993
 GB 321378 A 2/1929
 GB 395114 A 7/1933
 GB 979038 A 1/1965
 GB 1092306 A 11/1967
 GB 1098721 A 1/1968
 KR 19910057556 Y1 7/1991
 KR 100237923 B1 1/2001

OTHER PUBLICATIONS

Solid Brass Adjustable Door Catch, Signature Hardware, Erlanger, KY, accessed on the Internet at: <http://www.signaturehardware.com/product15219> on Jul. 23, 2013.
 Twin Ball Catch 42 mm, SDS London LTD, London, UK, accessed on the Internet at: <http://www.sdslondon.co.uk/product/twin-ball-catch-42mm.html> on Jul. 23, 2013.
 Ball-Nose Spring Plunger with Stainless Steel Ball, McMaster-Carr Supply Company, Santa Fe Springs, CA, Accessed on the Internet at: <http://www.mcmaster.com/#3408a59/=nu4ftb> on Jul. 29, 2013.
 Ives Architectural Hardware Products, Jun. 2009, pp. D8-D9, D13-D16, E6-E9, E14-E19, E21-E22, Ingersoll-Rand Company Limited, US.

* cited by examiner

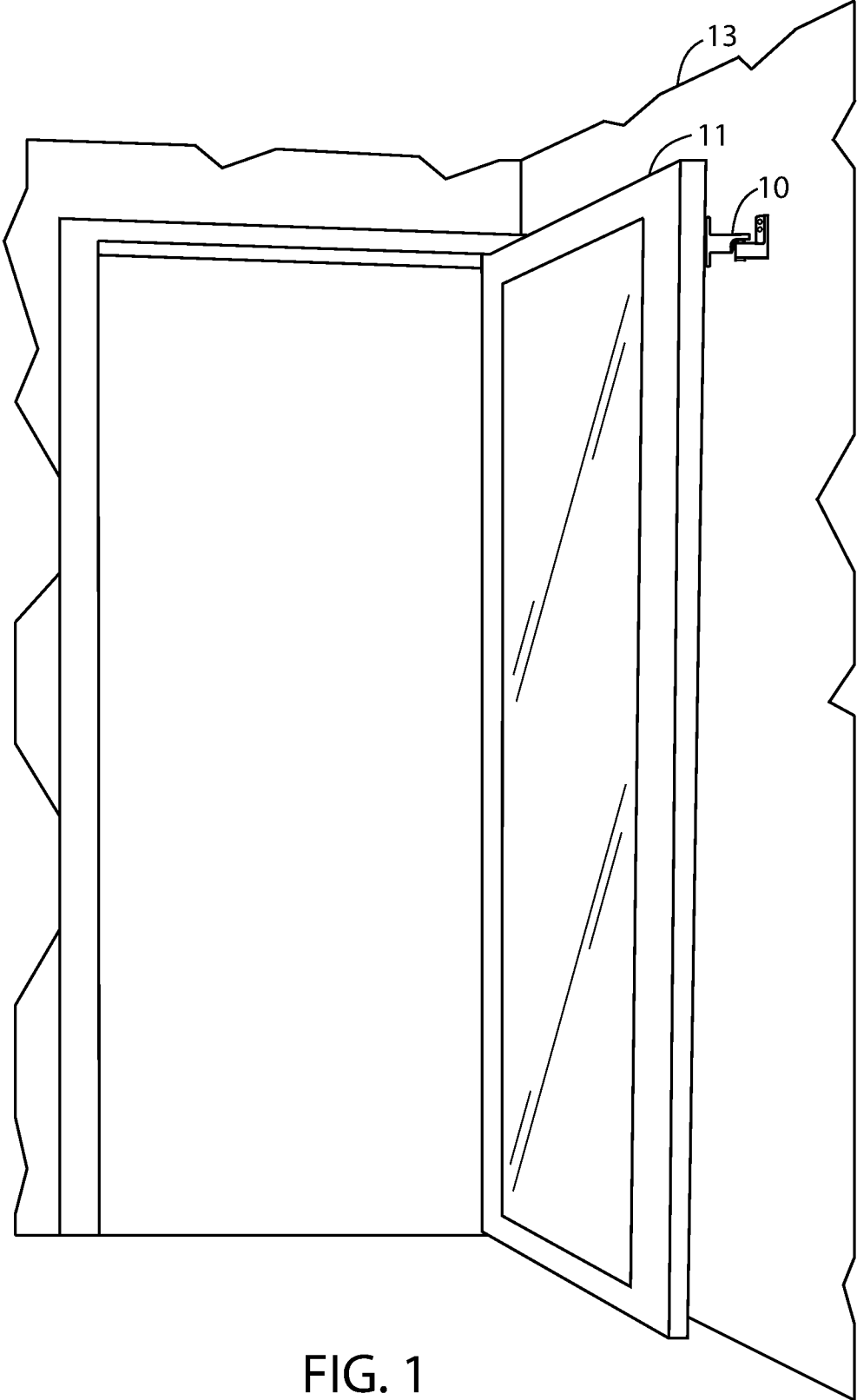

FIG. 1

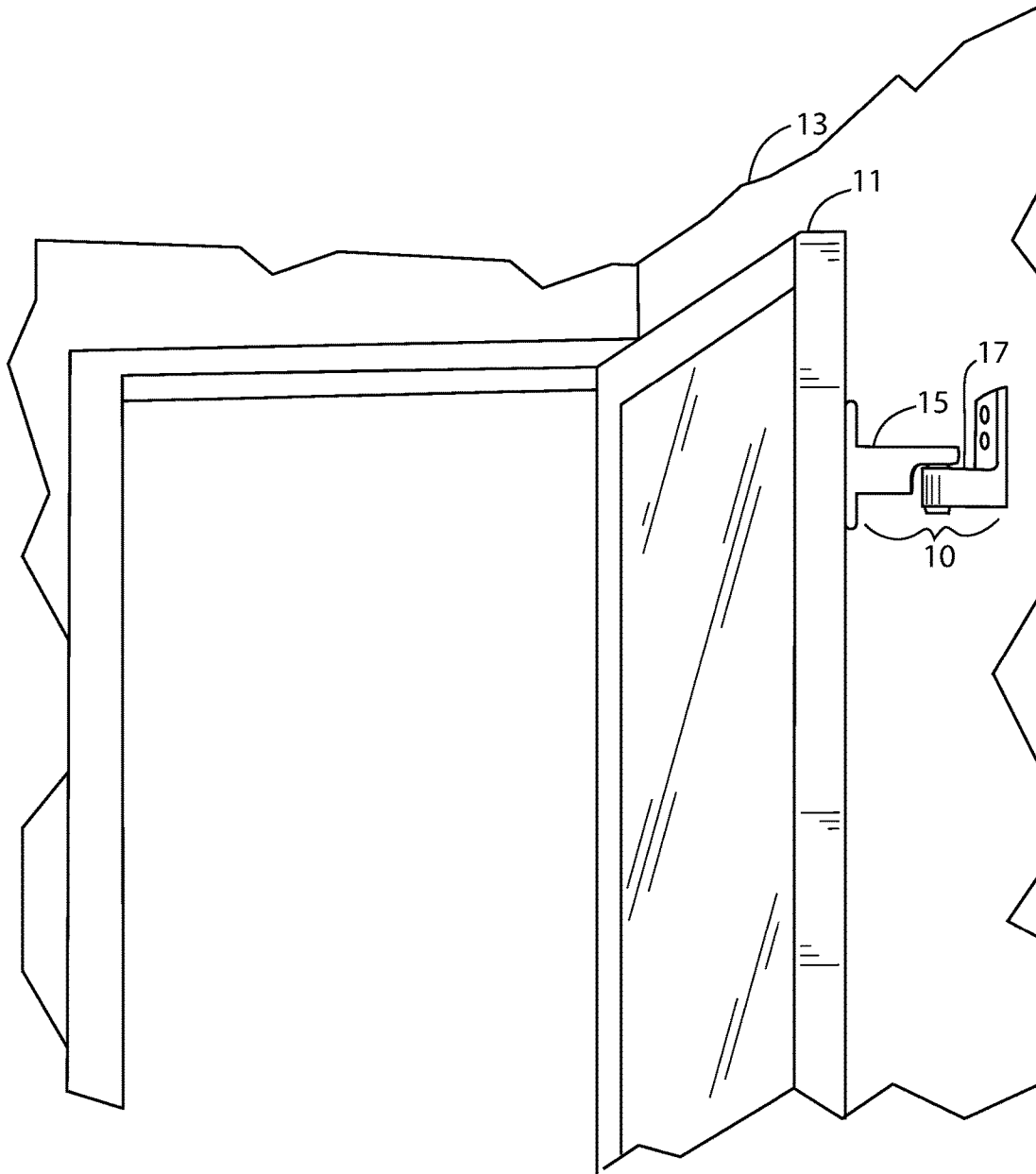

FIG. 2

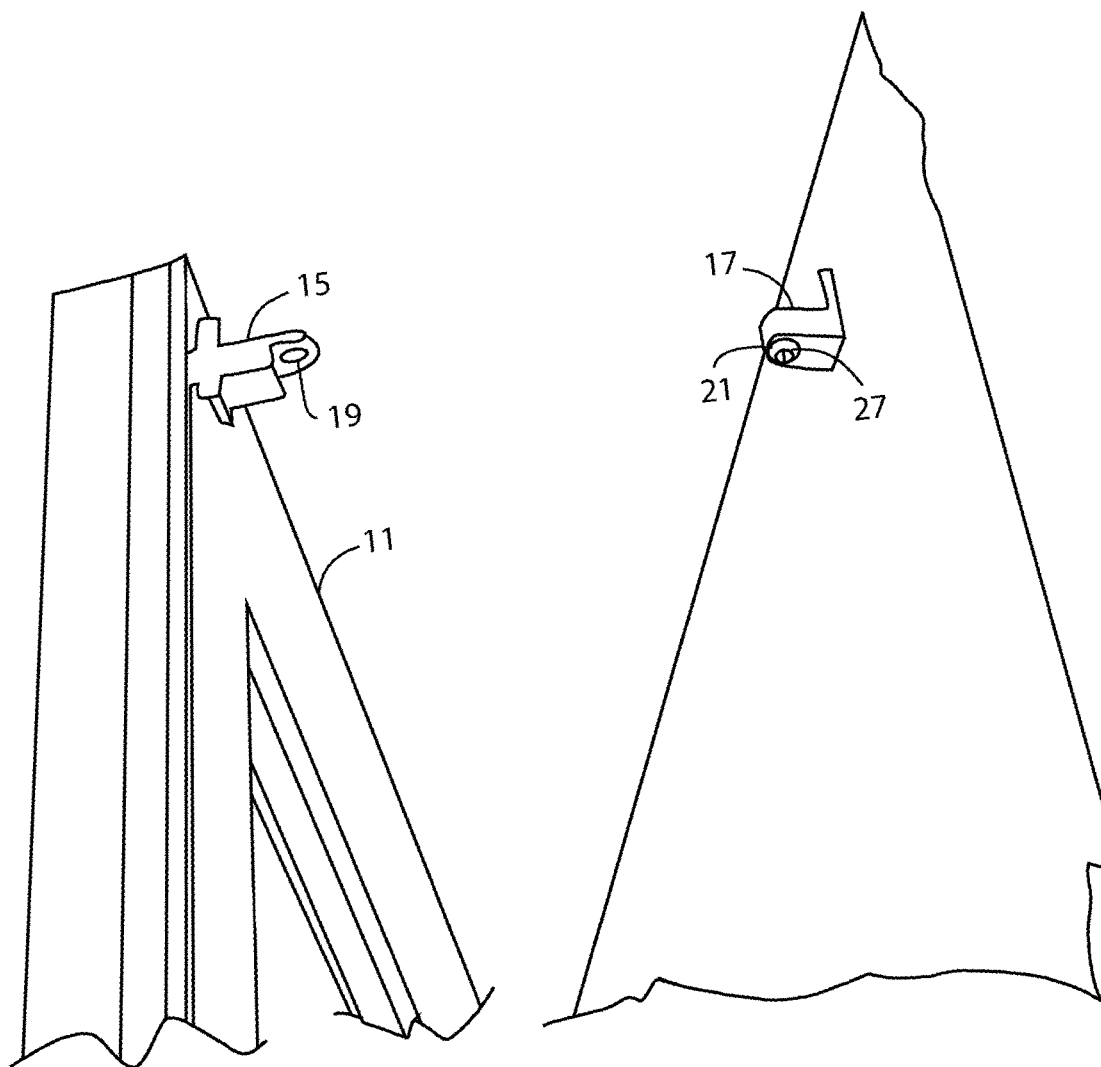

FIG. 3

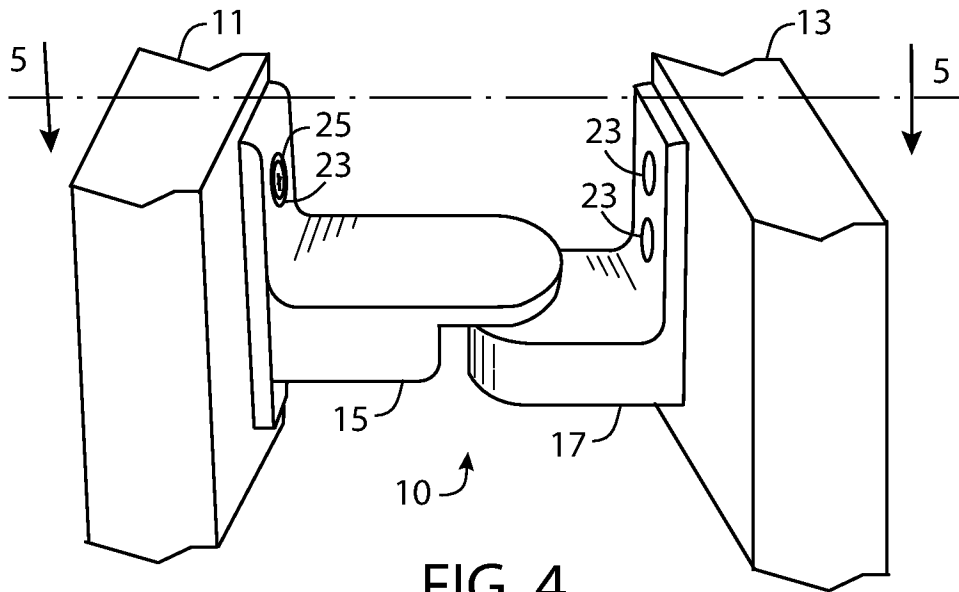

FIG. 4

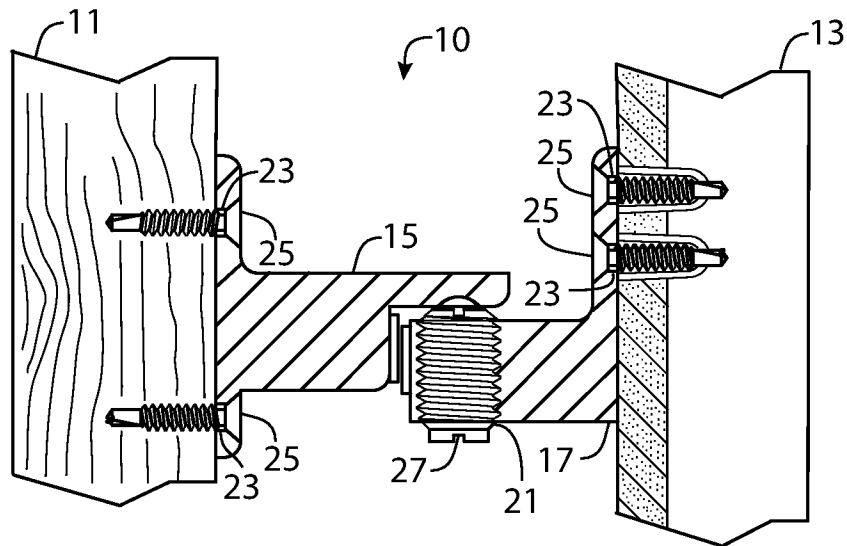

FIG. 5

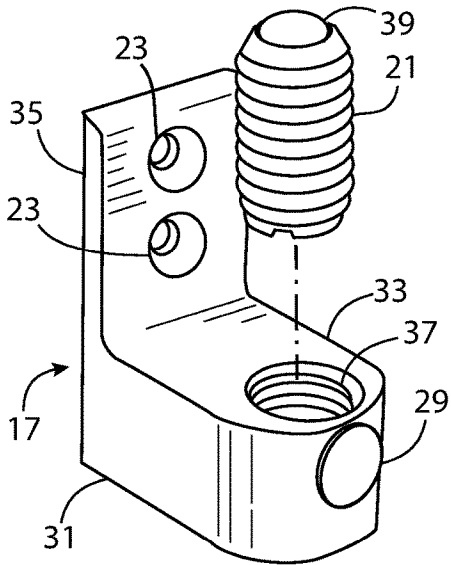

FIG. 6

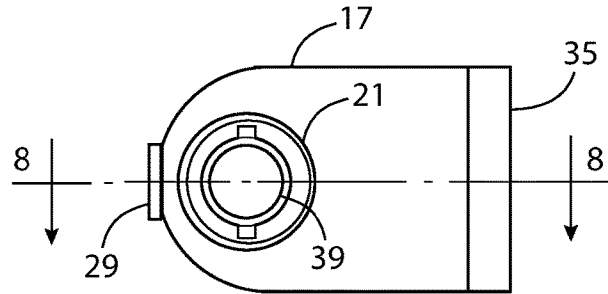

FIG. 7

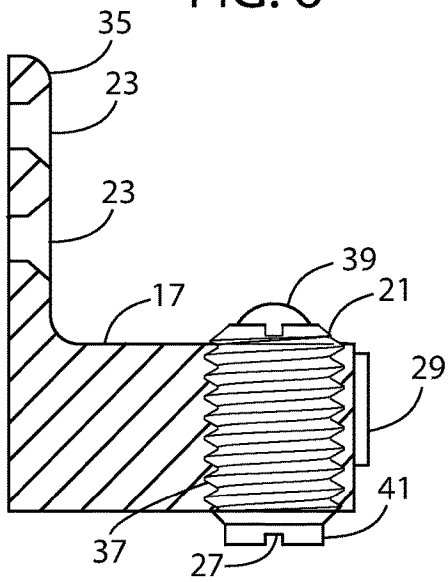

FIG. 8

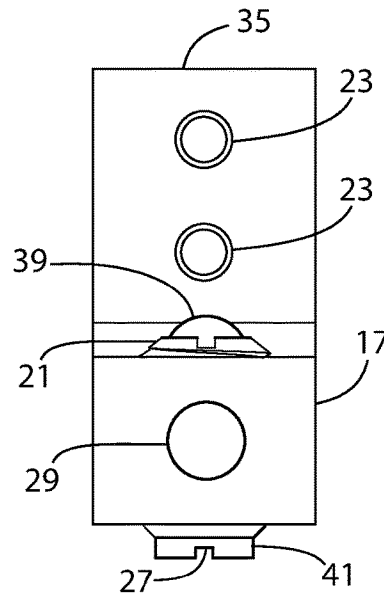

FIG. 9

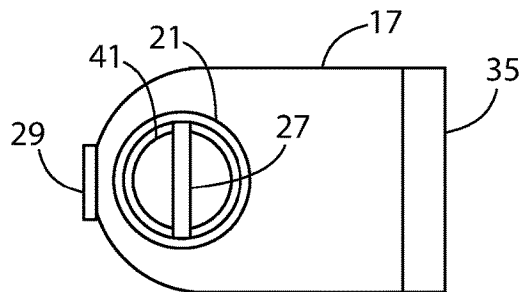

FIG. 10

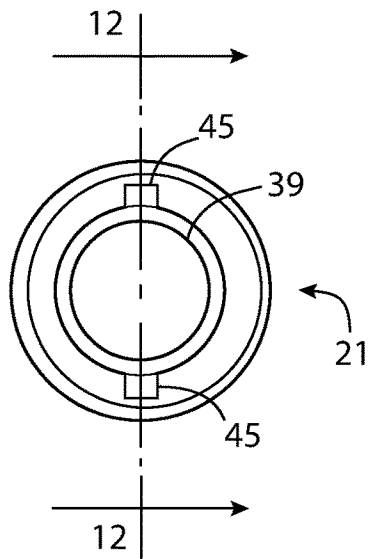

FIG. 11

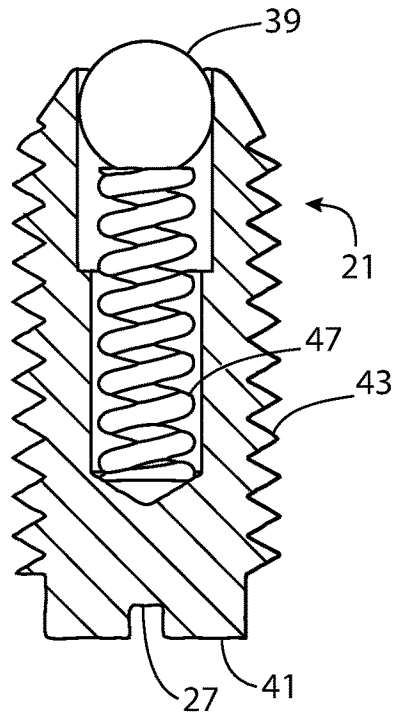

FIG. 12

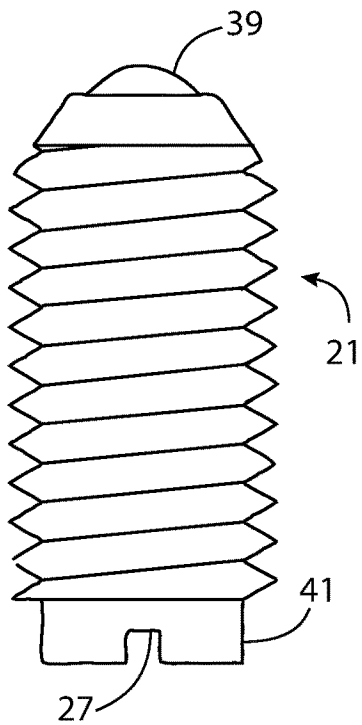

FIG. 13

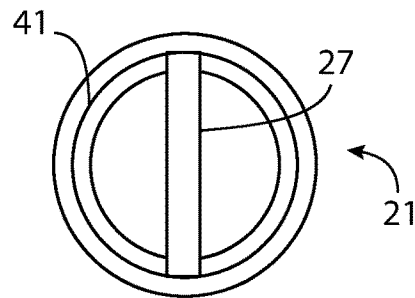

FIG. 14

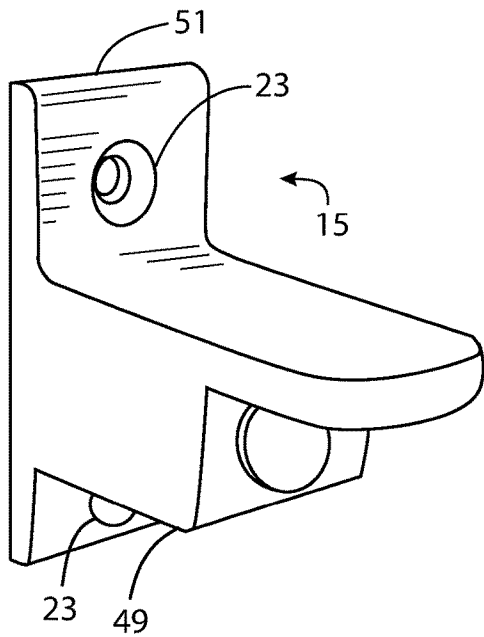

FIG. 15

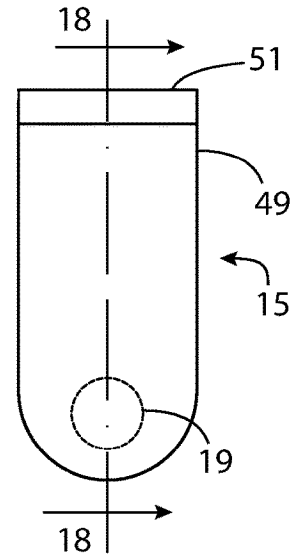

FIG. 17

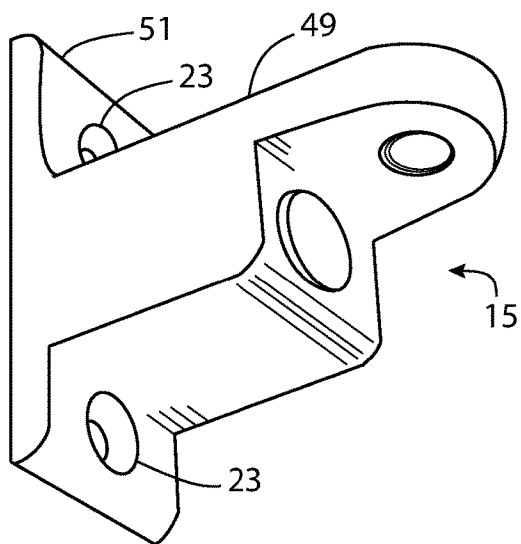

FIG. 16

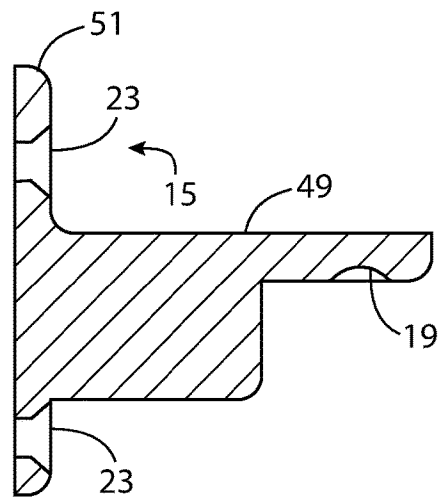

FIG. 18

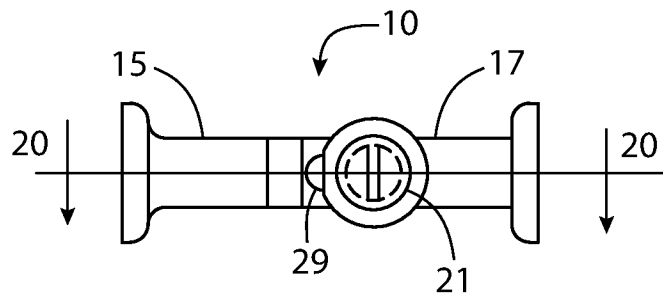

FIG. 19

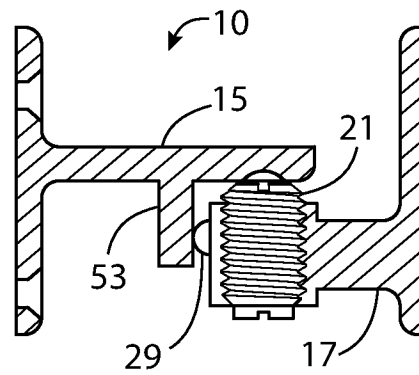

FIG. 20

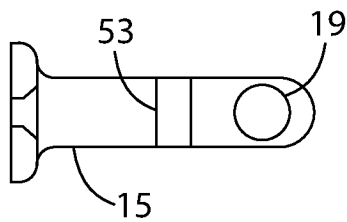

FIG. 21

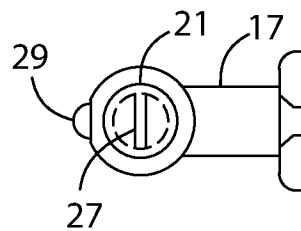

FIG. 22

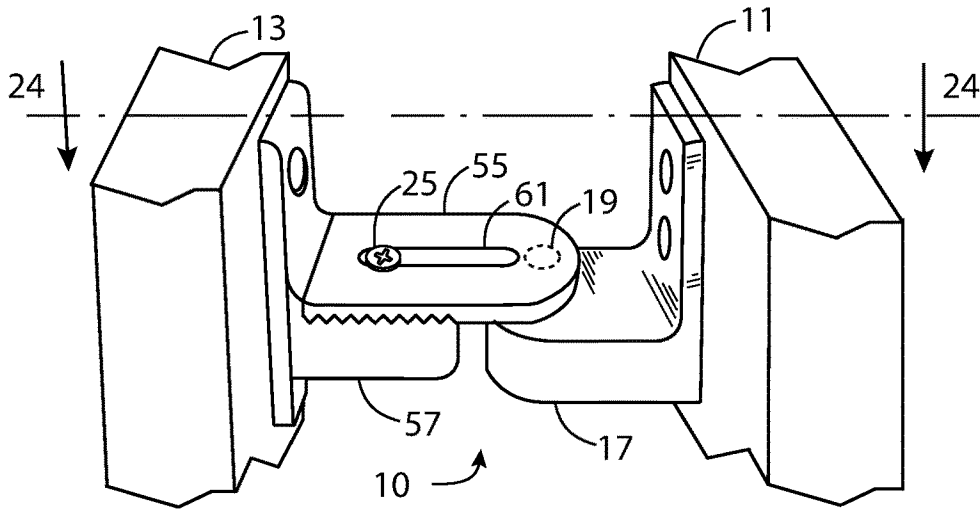

FIG. 23

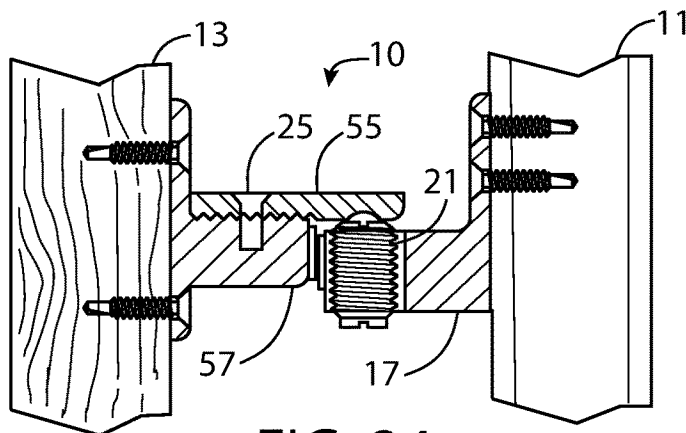

FIG. 24

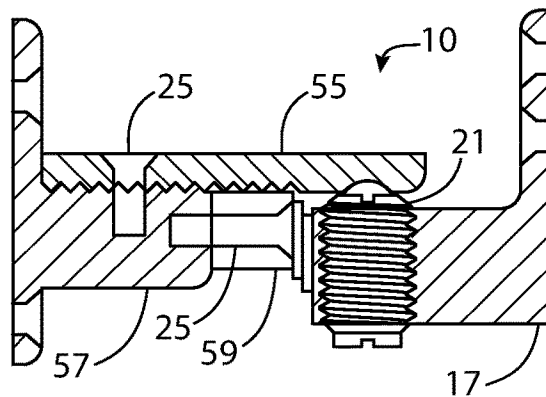

FIG. 25

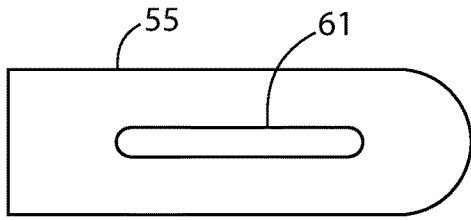

FIG. 26

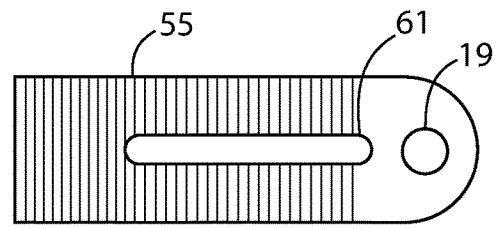

FIG. 27

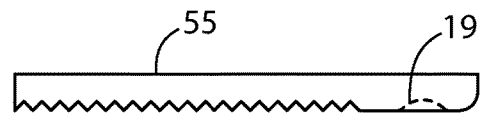

FIG. 28

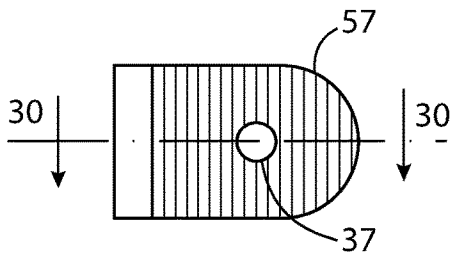

FIG. 29

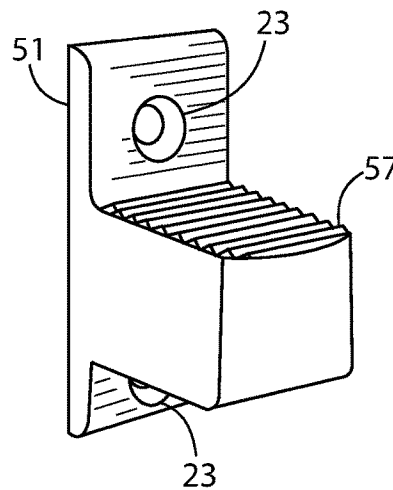

FIG. 31

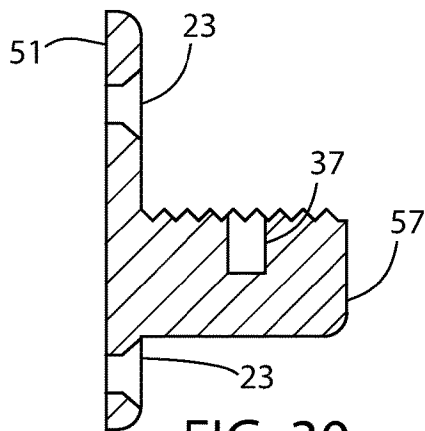
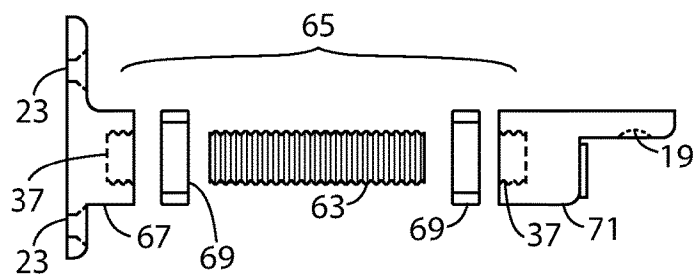
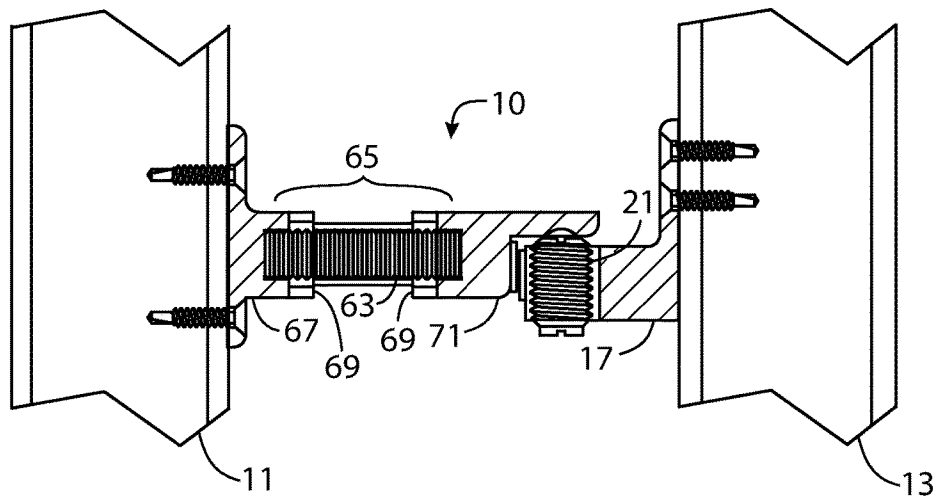
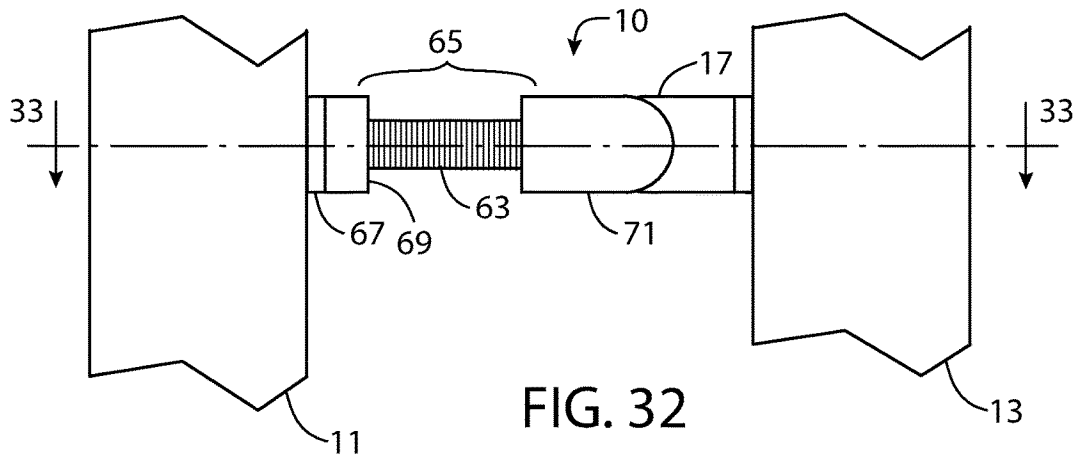

FIG. 30



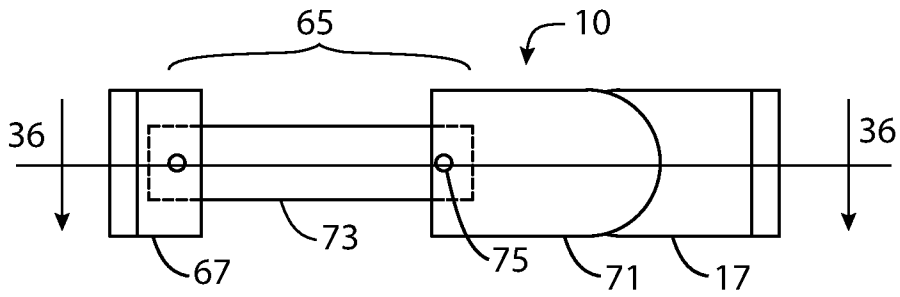

FIG. 35

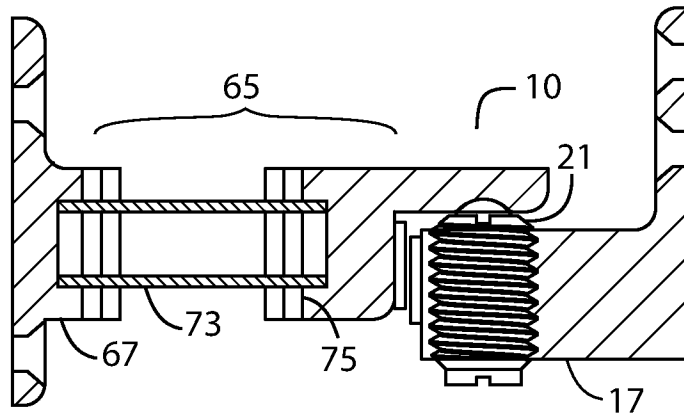

FIG. 36

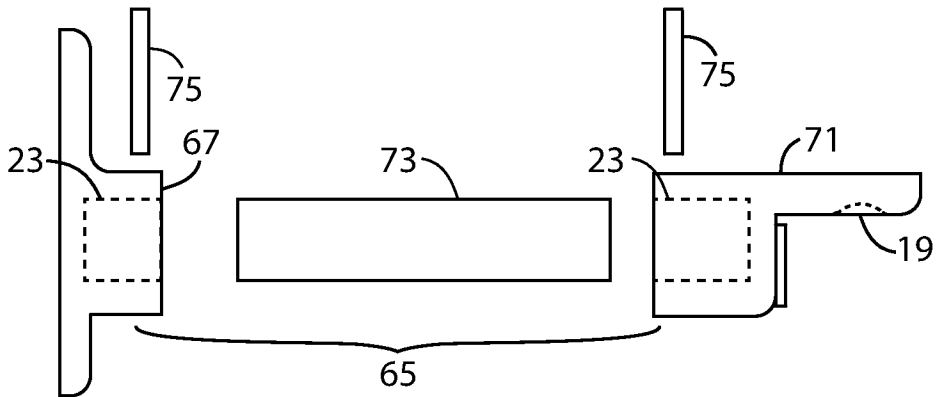

FIG. 37

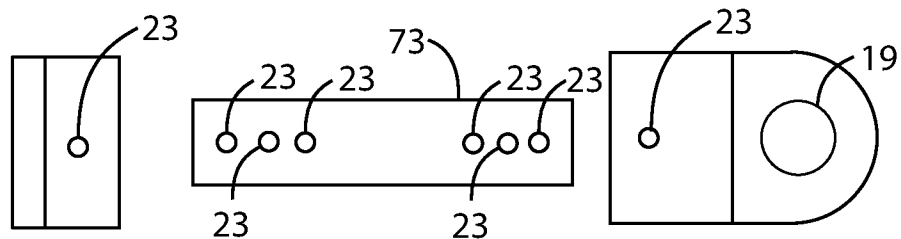

FIG. 38

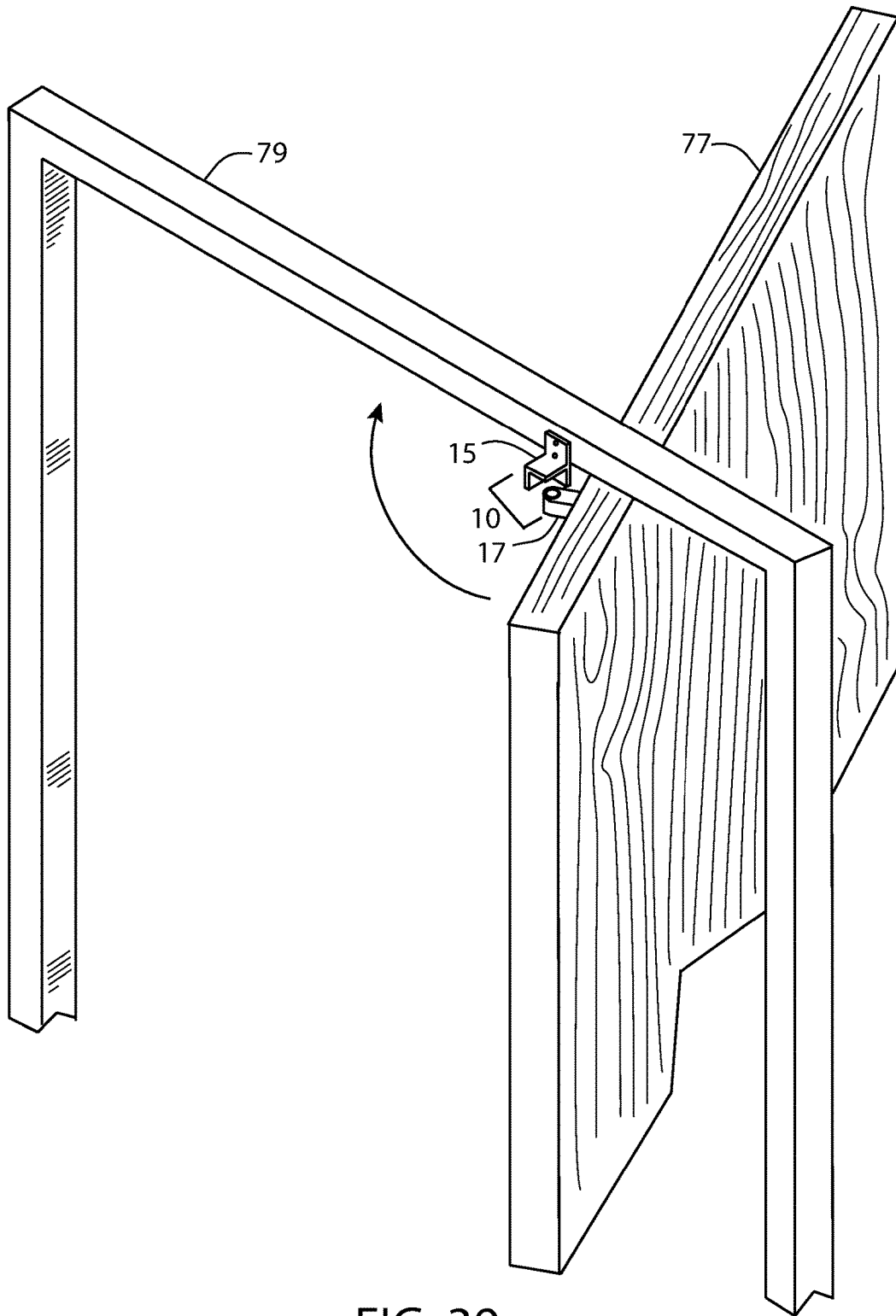

FIG. 39

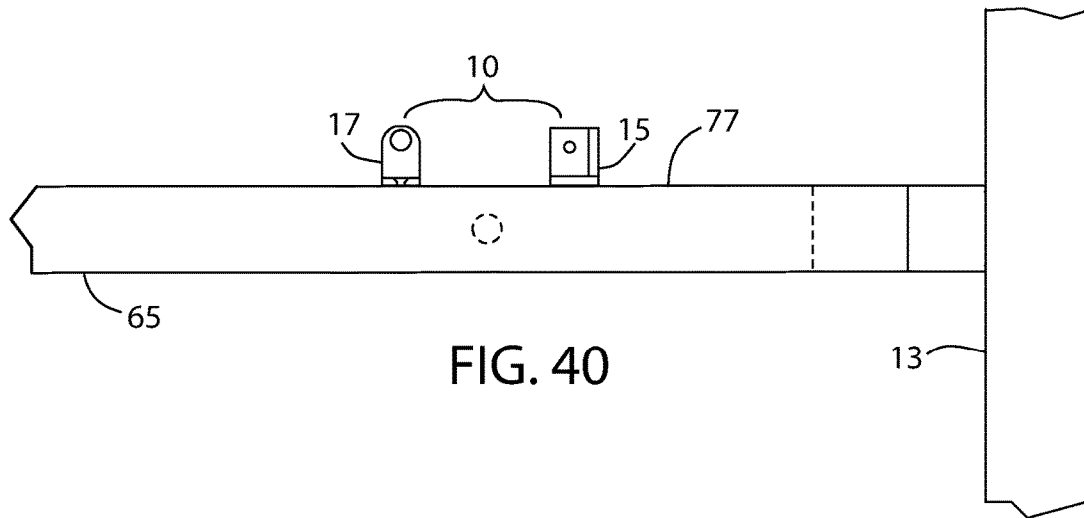

FIG. 40

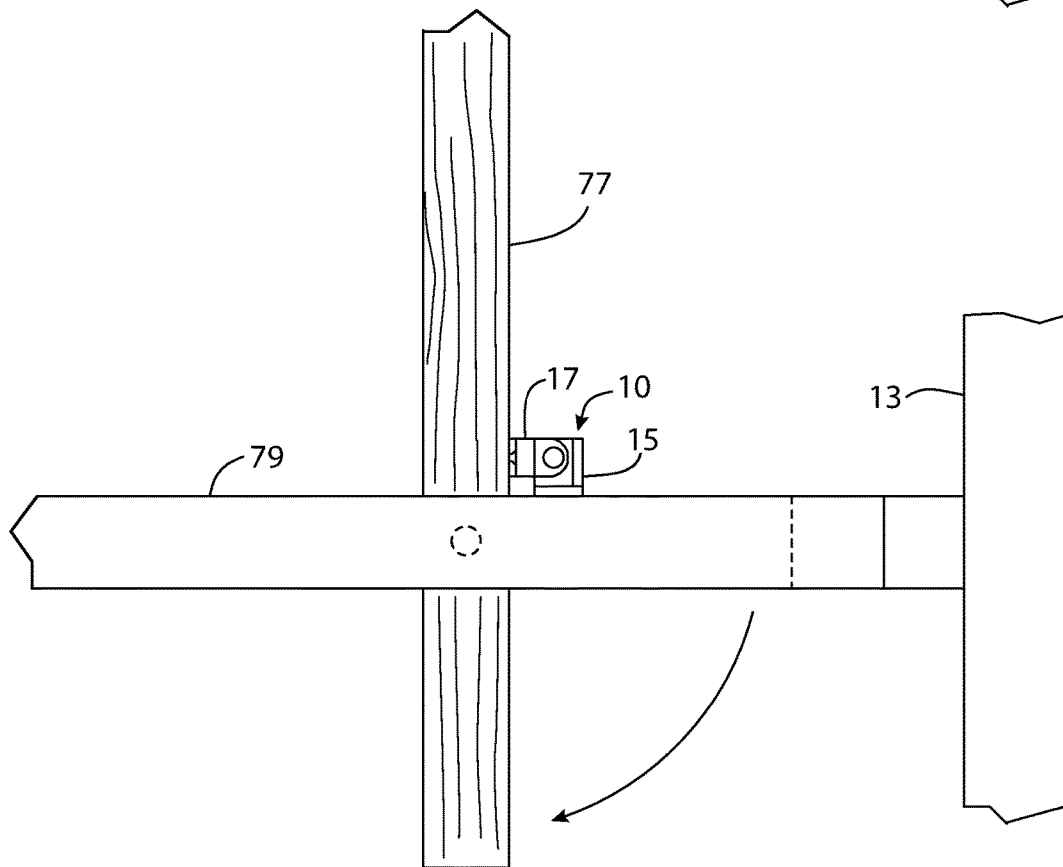

FIG. 41

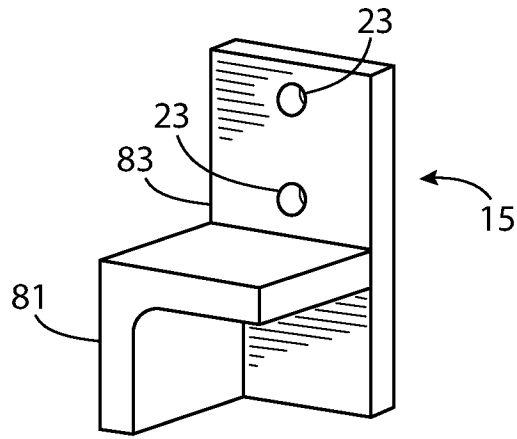

FIG. 42

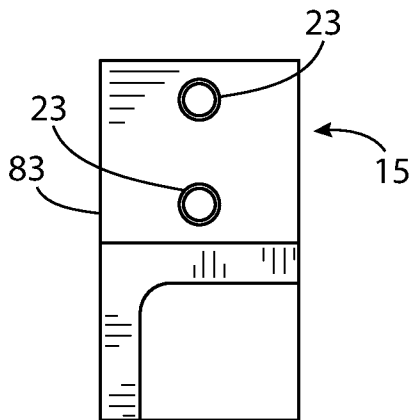

FIG. 43

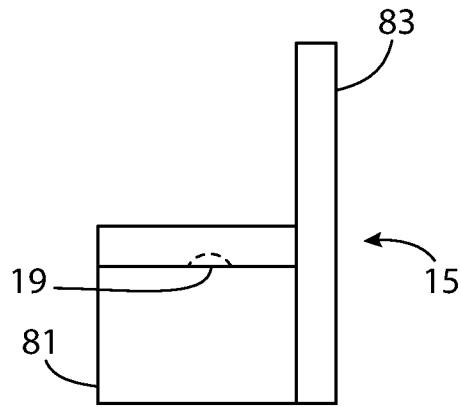

FIG. 44

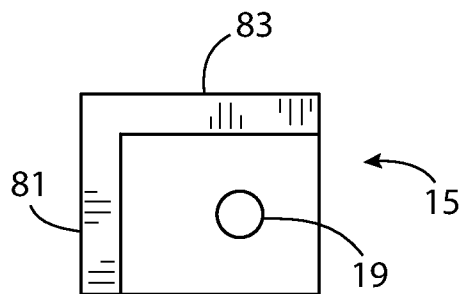

FIG. 45

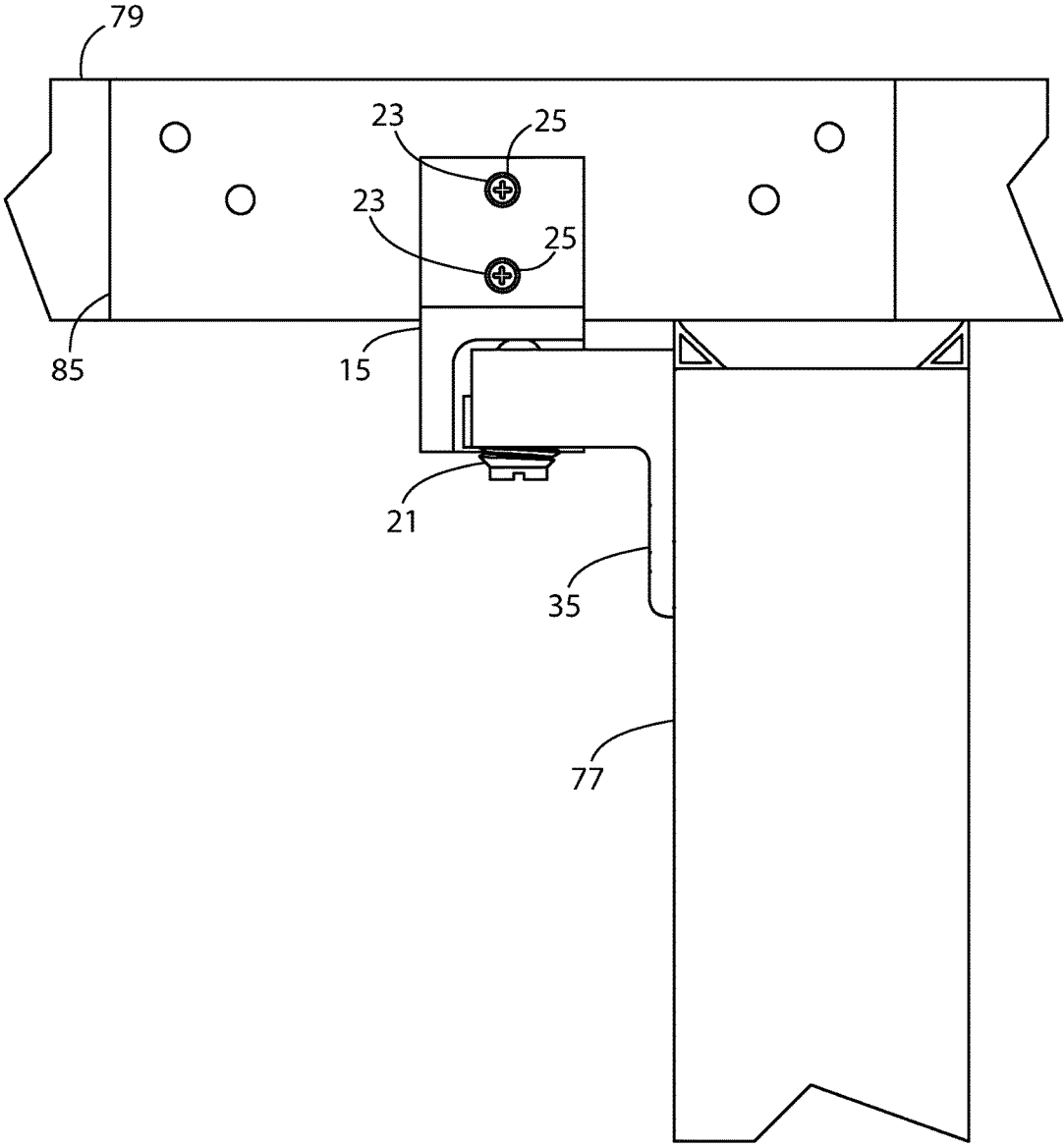

FIG. 46

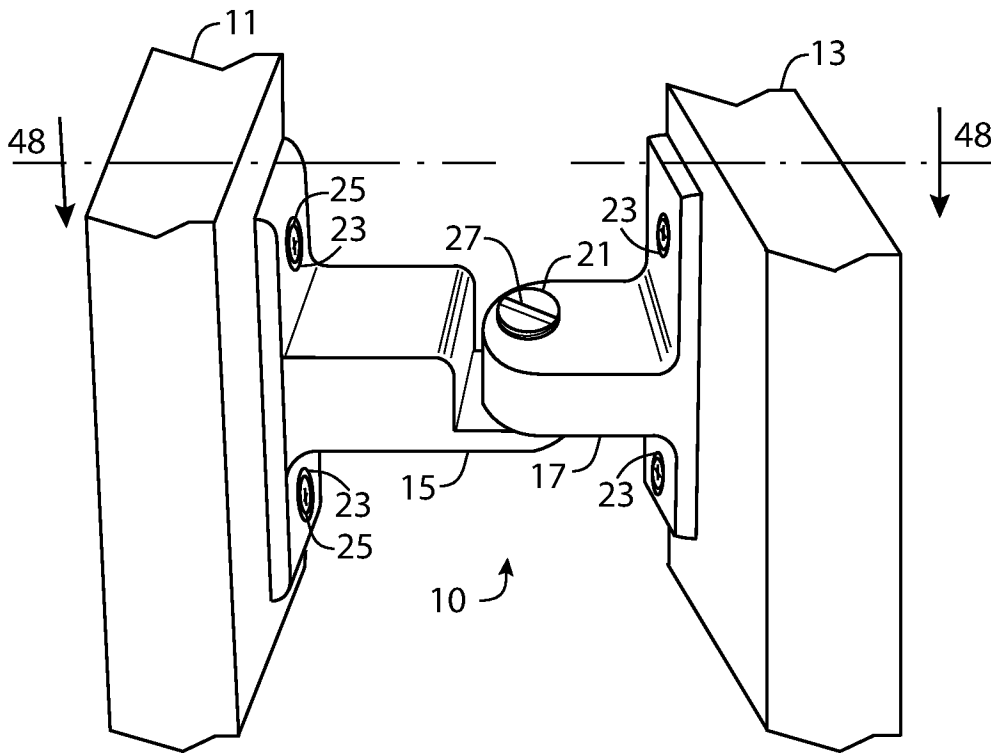

FIG. 47

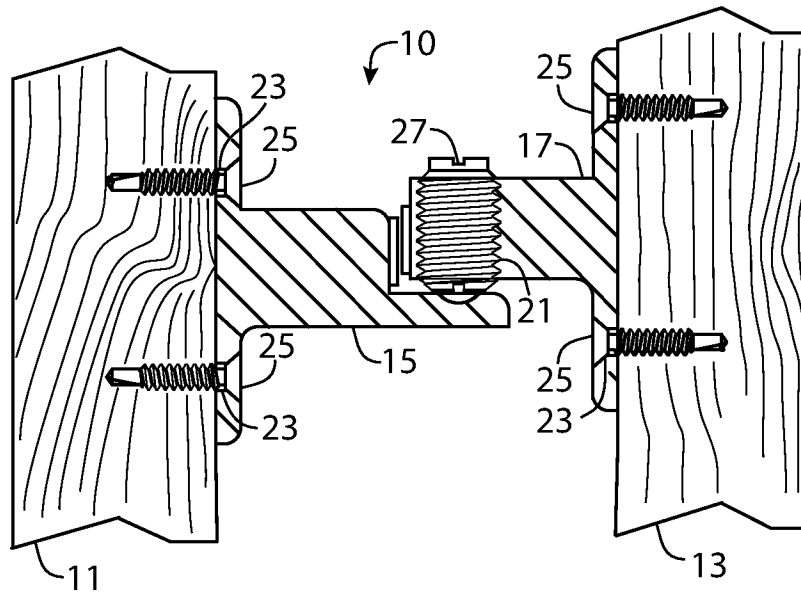

FIG. 48