



US009777484B2

(12) **United States Patent Header**

(10) **Patent No.:** US 9,777,484 B2
(45) **Date of Patent:** Oct. 3, 2017

(54) **HINGED GLASS HANDRAIL SILL**
(71) Applicant: **Gregory A. Header**, Richland, PA (US)
(72) Inventor: **Gregory A. Header**, Richland, PA (US)
(*) Notice: Subject to any disclaimer, the term of this patent is extended or adjusted under 35 U.S.C. 154(b) by 0 days.

(21) Appl. No.: **15/190,176**
(22) Filed: **Jun. 23, 2016**

(65) **Prior Publication Data**
US 2016/0298337 A1 Oct. 13, 2016

Related U.S. Application Data

(63) Continuation-in-part of application No. 13/847,383, filed on Mar. 19, 2013.

(51) **Int. Cl.**
E04B 1/00 (2006.01)
E04B 5/00 (2006.01)
(Continued)

(52) **U.S. Cl.**
CPC **E04F 11/1853** (2013.01); **E04F 11/1812** (2013.01); **E04F 2011/1823** (2013.01)

(58) **Field of Classification Search**
CPC ... E04H 17/16; E04B 2002/749; E04B 2/825; E04F 11/1812; E04F 11/1817; E04F 11/1851; E04F 11/1823; E04F 11/1853; E04F 2011/1823; E06B 3/5454; F16B 2/12; Y10T 403/76
(Continued)

(56) **References Cited**
U.S. PATENT DOCUMENTS
3,630,490 A 12/1971 Hogan, Jr.
RE28,643 E 12/1975 Blum
(Continued)

FOREIGN PATENT DOCUMENTS

EP 1277894 B1 11/2007
WO 2010111751 A1 10/2010

OTHER PUBLICATIONS

David Brian Mattei, Non-Final Office Action, Double-Hinged Glass Handrail Sill, U.S. Appl. No. 13/847,383, Applicant: Gregory A. Header, dated Mar. 12, 2014, United States Patent and Trademark Office, Alexandria, VA US.
(Continued)

Primary Examiner — Brian D Mattei
(74) *Attorney, Agent, or Firm* — Stone Creek Services LLC; Alan M Flum

(57) **ABSTRACT**
The invention is a double-hinged sill for adjustable securing the panels of a handrail system to a floor, the sill has U-shaped channel. A pair of hinged plates is pivotally mounted within the channel. A cylindrical hinge member is provided at the bottom end of each of the hinge plates and extends the length of the hinge plate. A groove for receiving the cylindrical hinge member is provided at the bottom of the sill. The pair of hinge plates is aligned within the sill as mirror images. A series of adjustment and locking screws are provided along the length of the sill and extend there through from either the top of the sill or the sides of the sill and a readapted to selectively impinge against the pair of hinge plates to movably adjust the plates inwardly against a glass panel or outwardly away from a glass panel to vertically align the same and lock it into place.

15 Claims, 18 Drawing Sheets

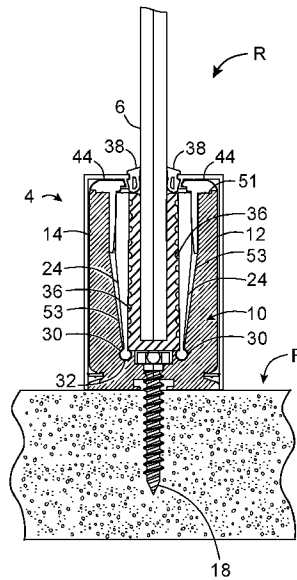

- | | | |
|------|---|--|
| (51) | Int. Cl.
<i>E04B 7/00</i> (2006.01)
<i>E04F 11/18</i> (2006.01) | 2002/0195595 A1 12/2002 Shepherd
2010/0225040 A1 9/2010 Allen
2011/0260129 A1 10/2011 Schopf et al.
2012/0189378 A1* 7/2012 Visa E04F 11/1853 |
| (58) | Field of Classification Search
USPC 52/126.3–126.5, 241, 204.597, 204.64,
52/800.14, 204.65, 284; 256/24–26,
256/65.01, 67, 69

See application file for complete search history. | 2012/0299233 A1 11/2012 Header
2014/0334874 A1* 11/2014 Allen E04C 1/42
403/374.3
2015/0110552 A1* 4/2015 Yang F16B 2/14
403/374.1
2017/0101784 A1* 4/2017 Gonzato E04F 11/1834 |
| (56) | References Cited | |

U.S. PATENT DOCUMENTS

4,054,268	A	10/1977	Sher
4,067,548	A	1/1978	Murphy
4,103,874	A	8/1978	Horgan, Jr.
4,920,717	A	5/1990	Hopper, Jr.
6,419,209	B1	7/2002	Shepard
6,434,905	B1	8/2002	Sprague
6,517,056	B2	2/2003	Shepard
7,559,536	B1	7/2009	Hansen et al.
7,584,588	B2	9/2009	Kim
7,730,682	B2	6/2010	Nash
2002/0088188	A1	7/2002	Chang

OTHER PUBLICATIONS

David Brian Mattei, Final Office Action, Double-Hinged Glass Handrail Sill, U.S. Appl. No. 13/847,383, Applicant: Gregory A. Header, dated Sep. 23, 2014, United States Patent and Trademark Office, Alexandria, VA US.

David Brian Mattei, Examiner's Answer in Response to Appeals Brief, Double-Hinged Glass Handrail Sill, U.S. Appl. No. 13/847,383, Applicant: Gregory A. Header, dated Jul. 1, 2015, United States Patent and Trademark Office, Alexandria, VA US.

* cited by examiner

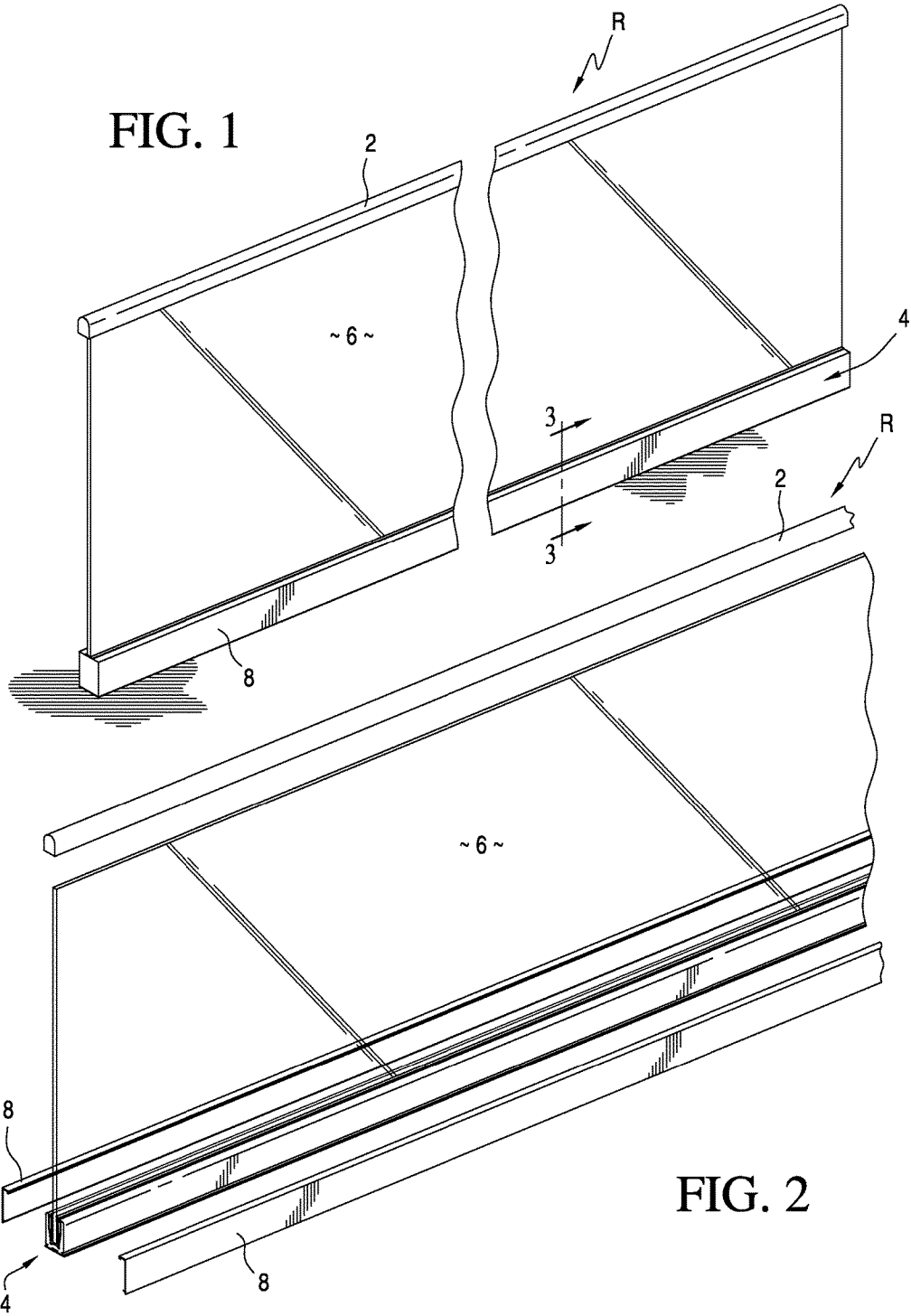

FIG. 3

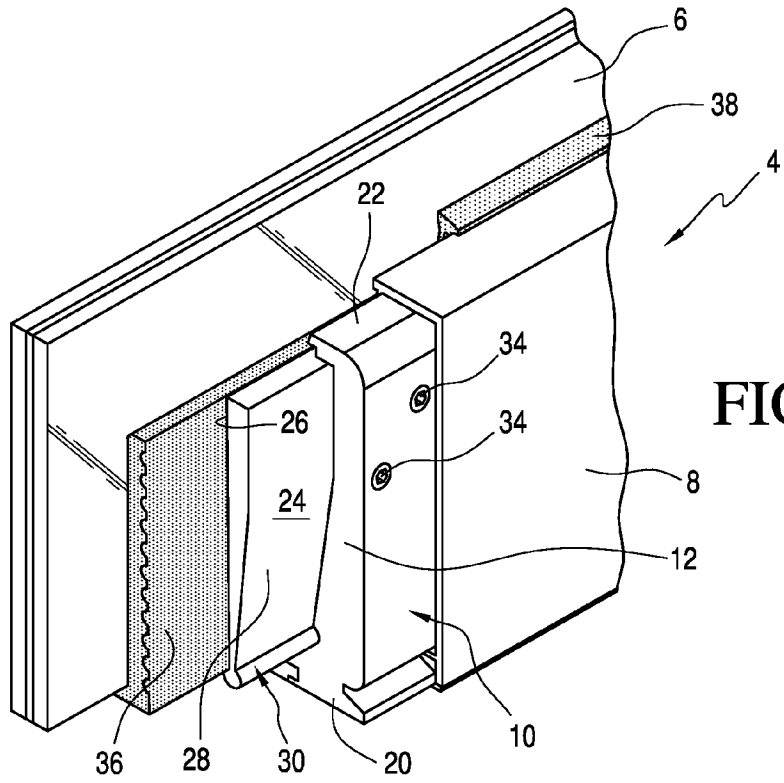
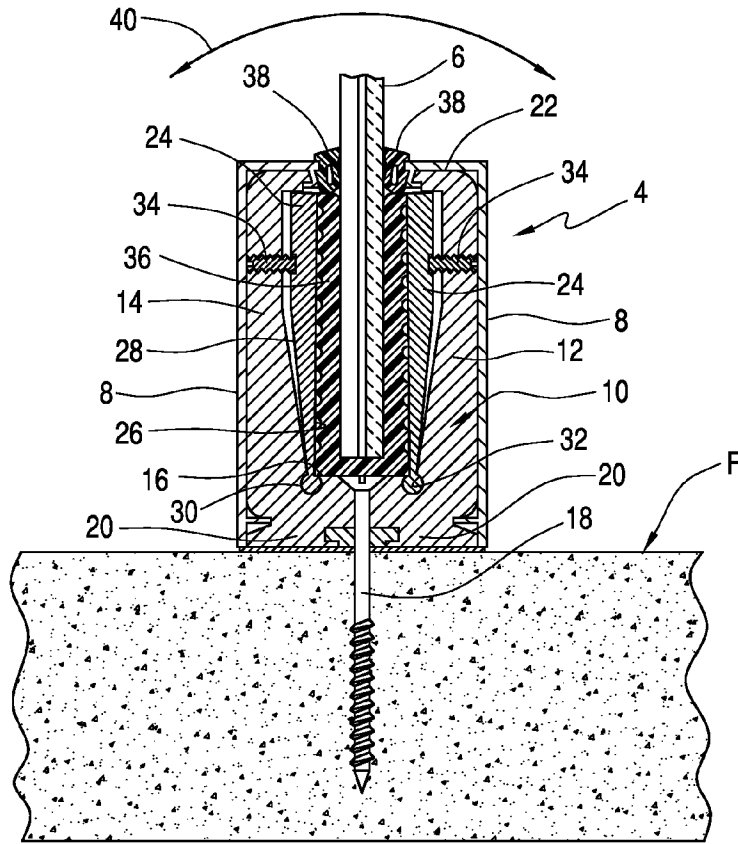

FIG. 4

FIG. 5

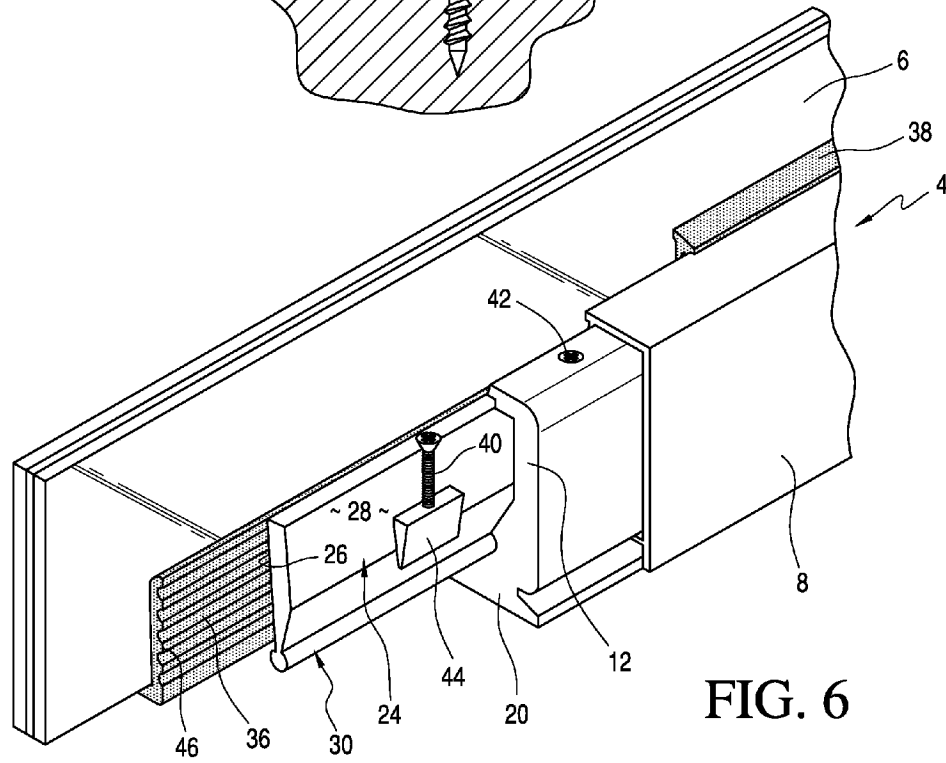
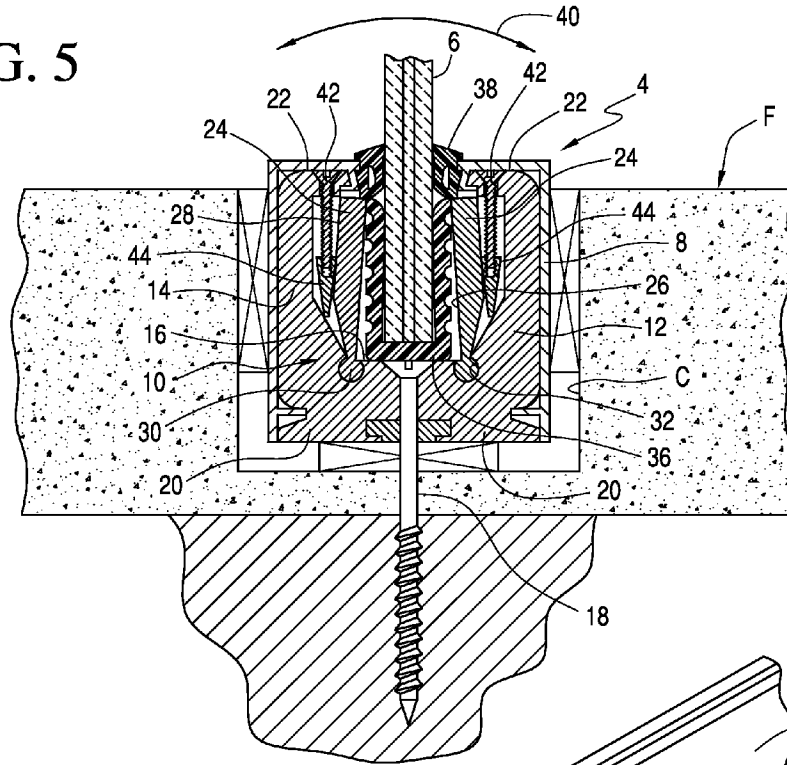

FIG. 6

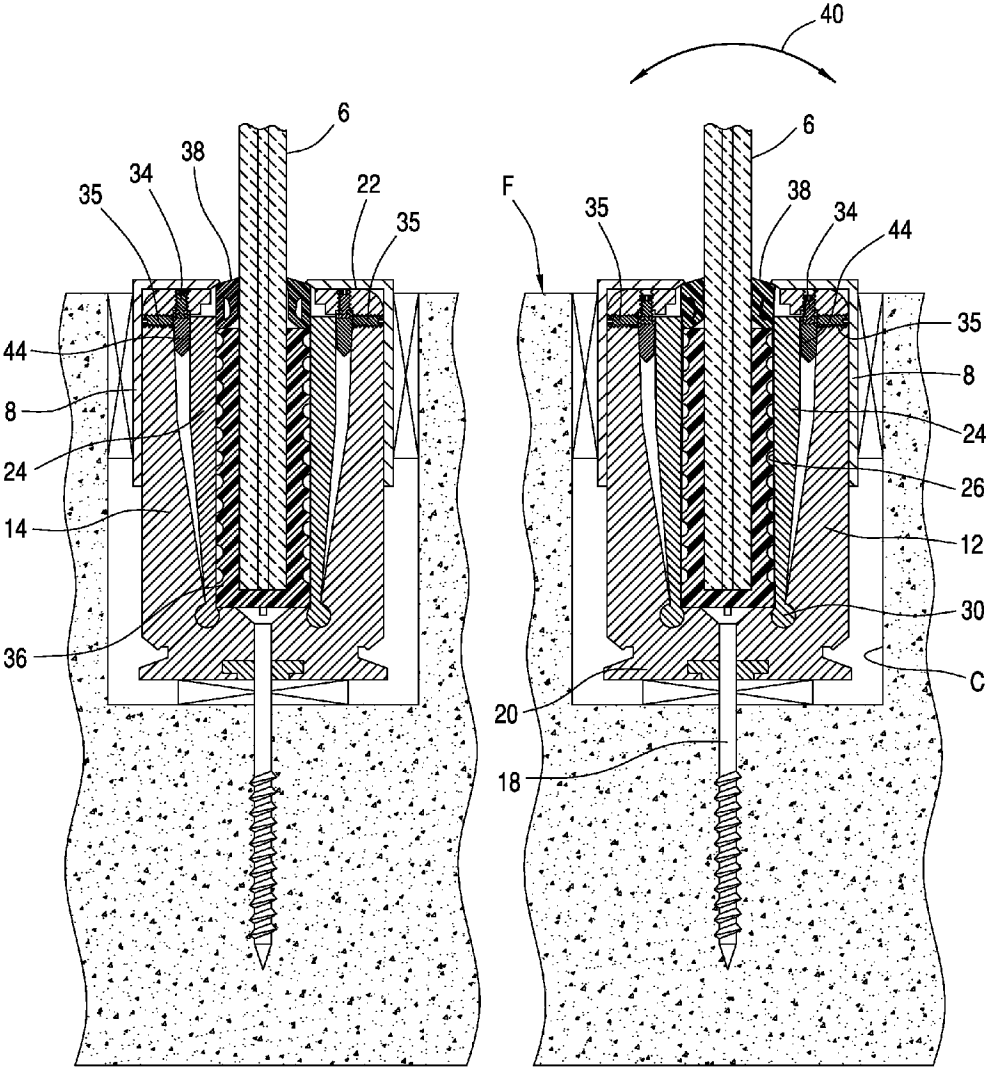

FIG. 7A

FIG. 7B

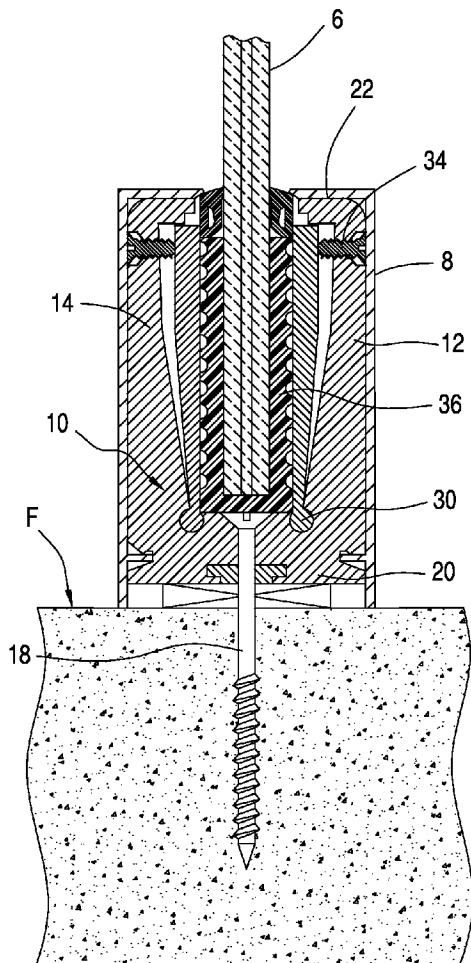

FIG. 8A

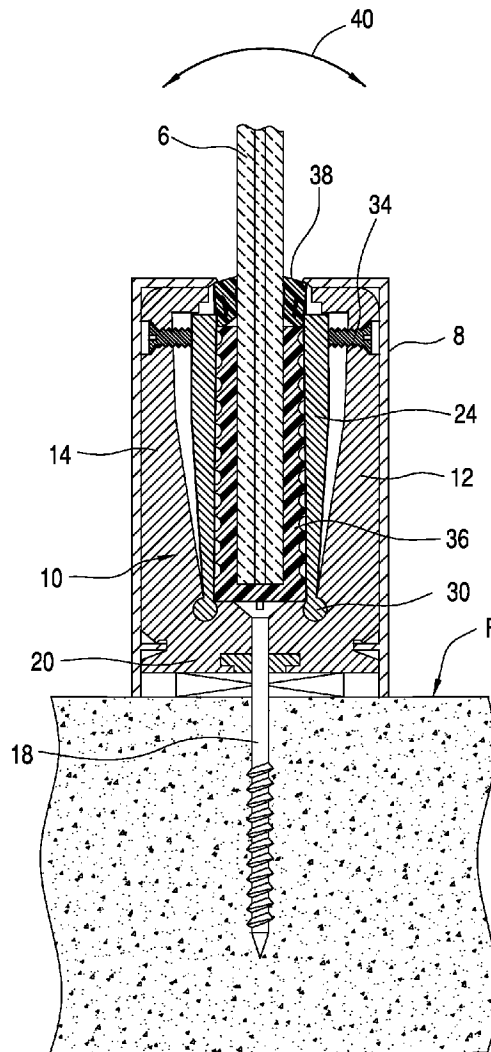

FIG. 8B

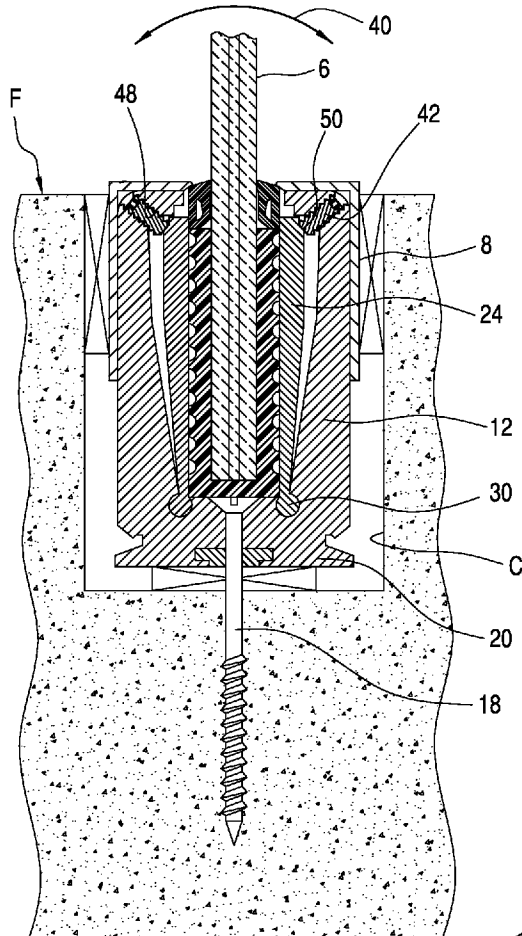

FIG. 9

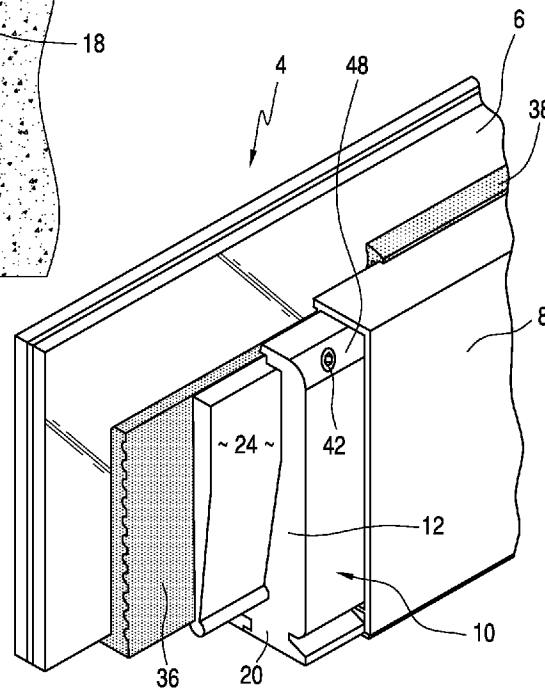

FIG. 10

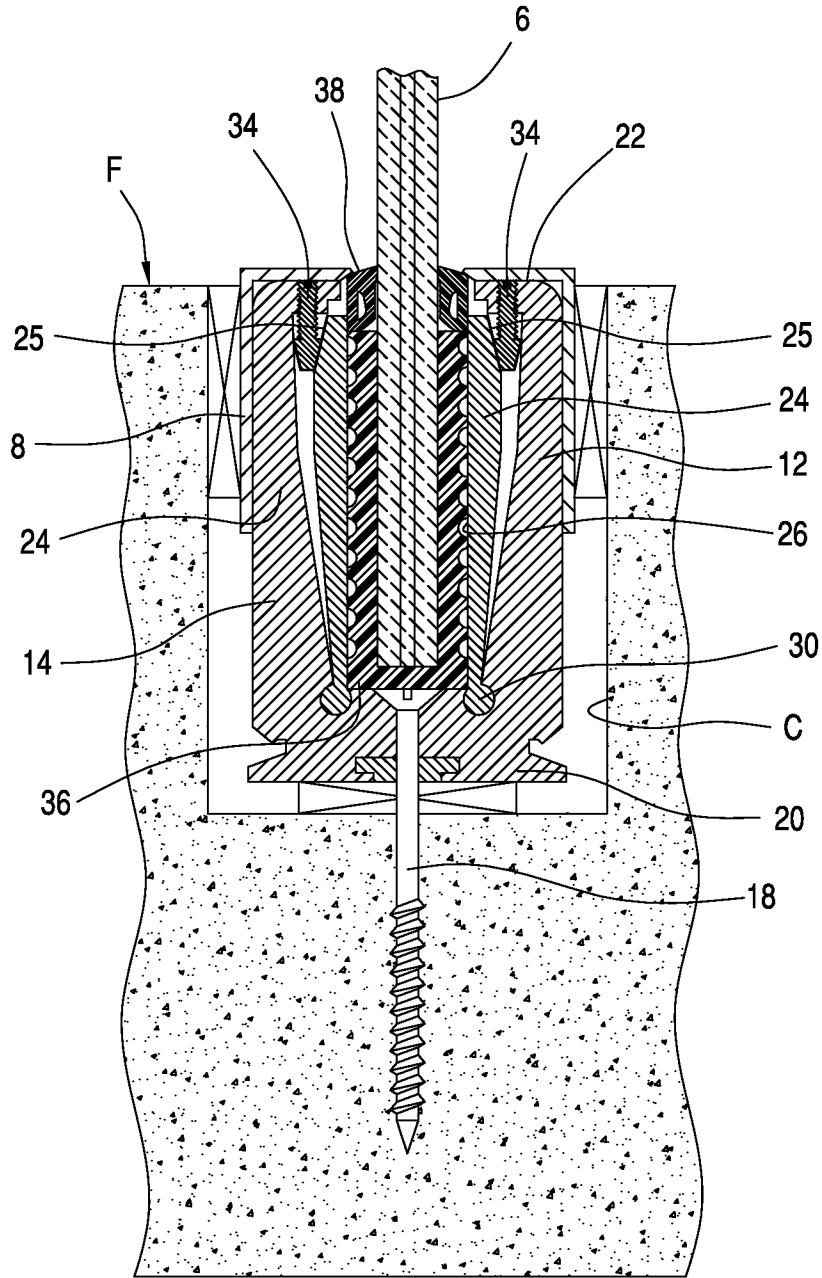

FIG. 11

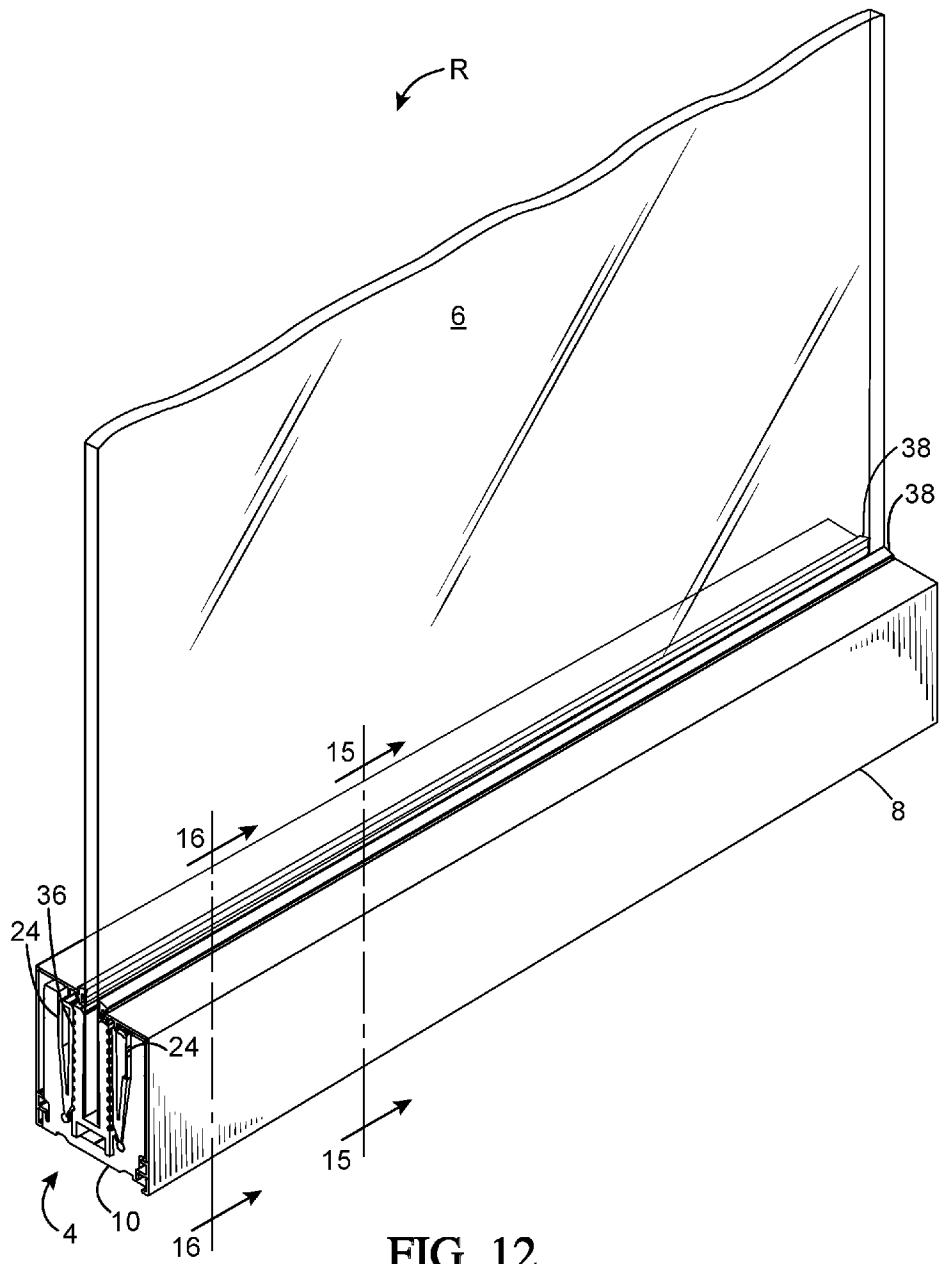

FIG. 12

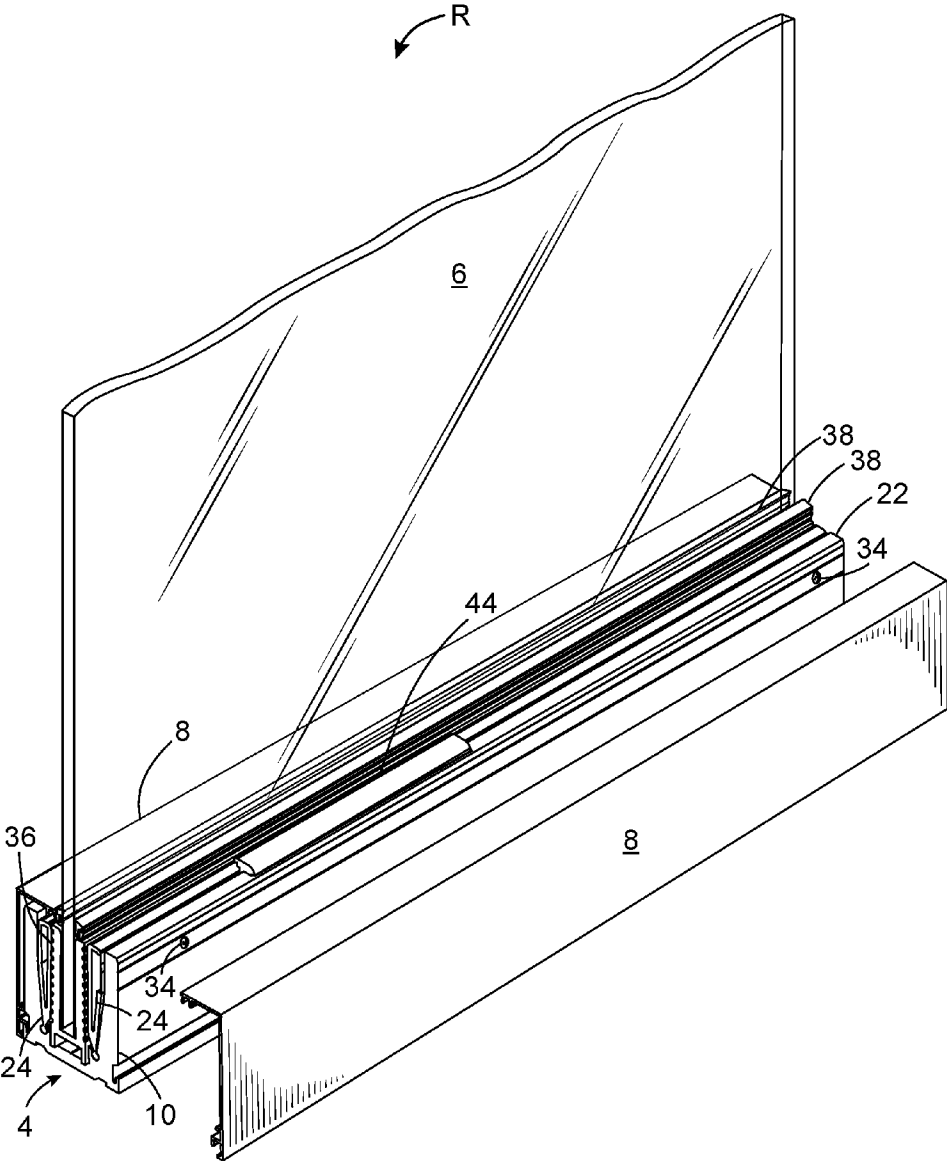

FIG. 13

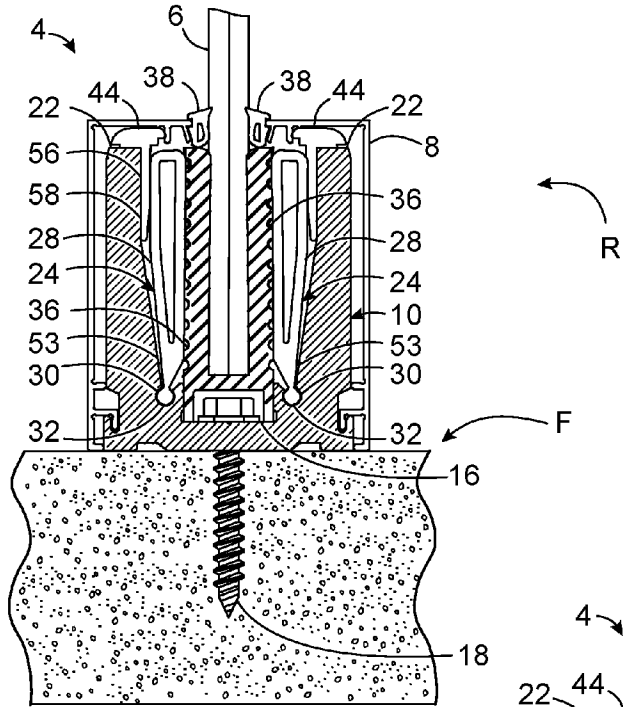

FIG. 15

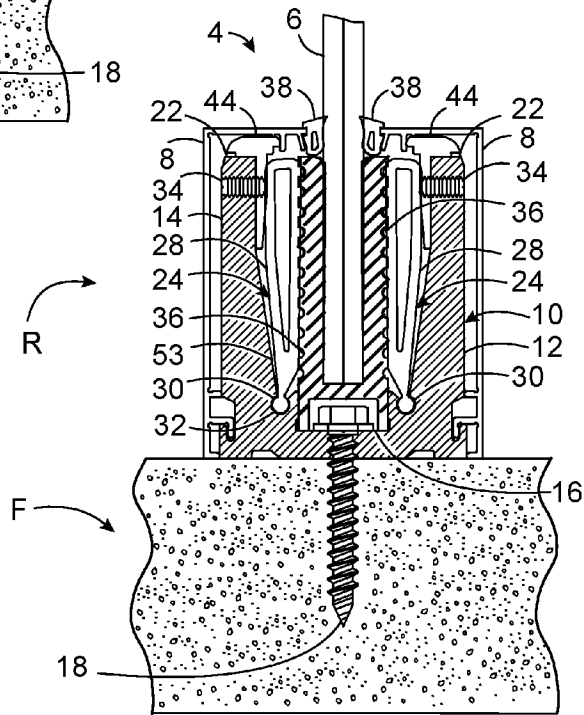

FIG. 16

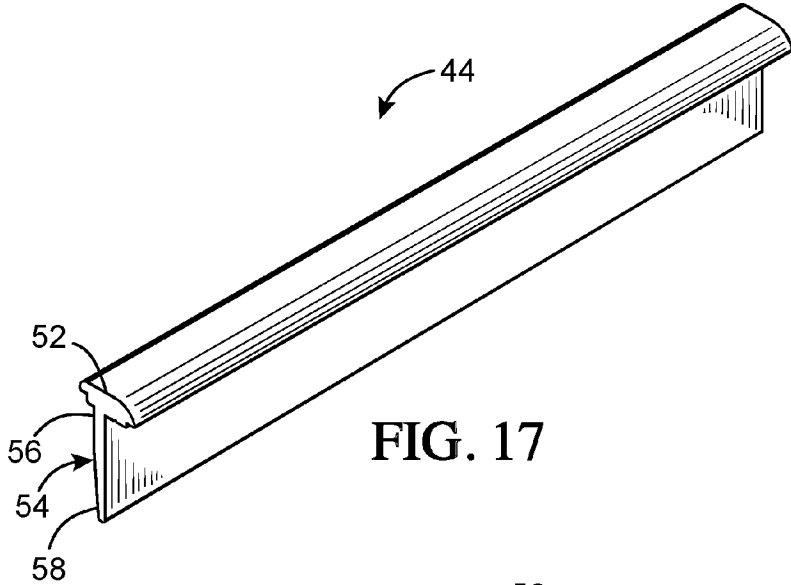

FIG. 17

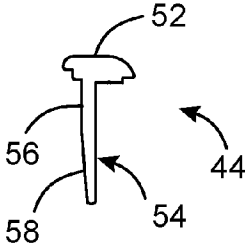

FIG. 18

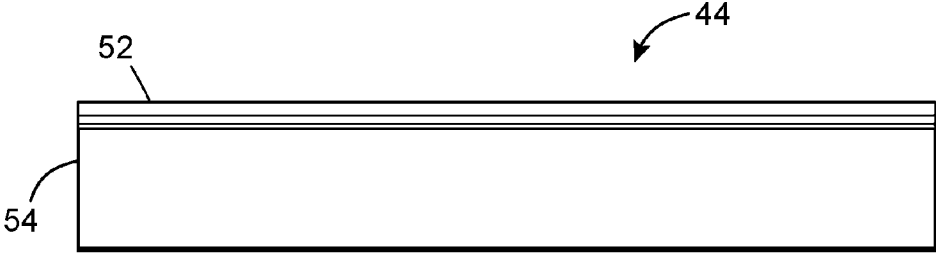

FIG. 19

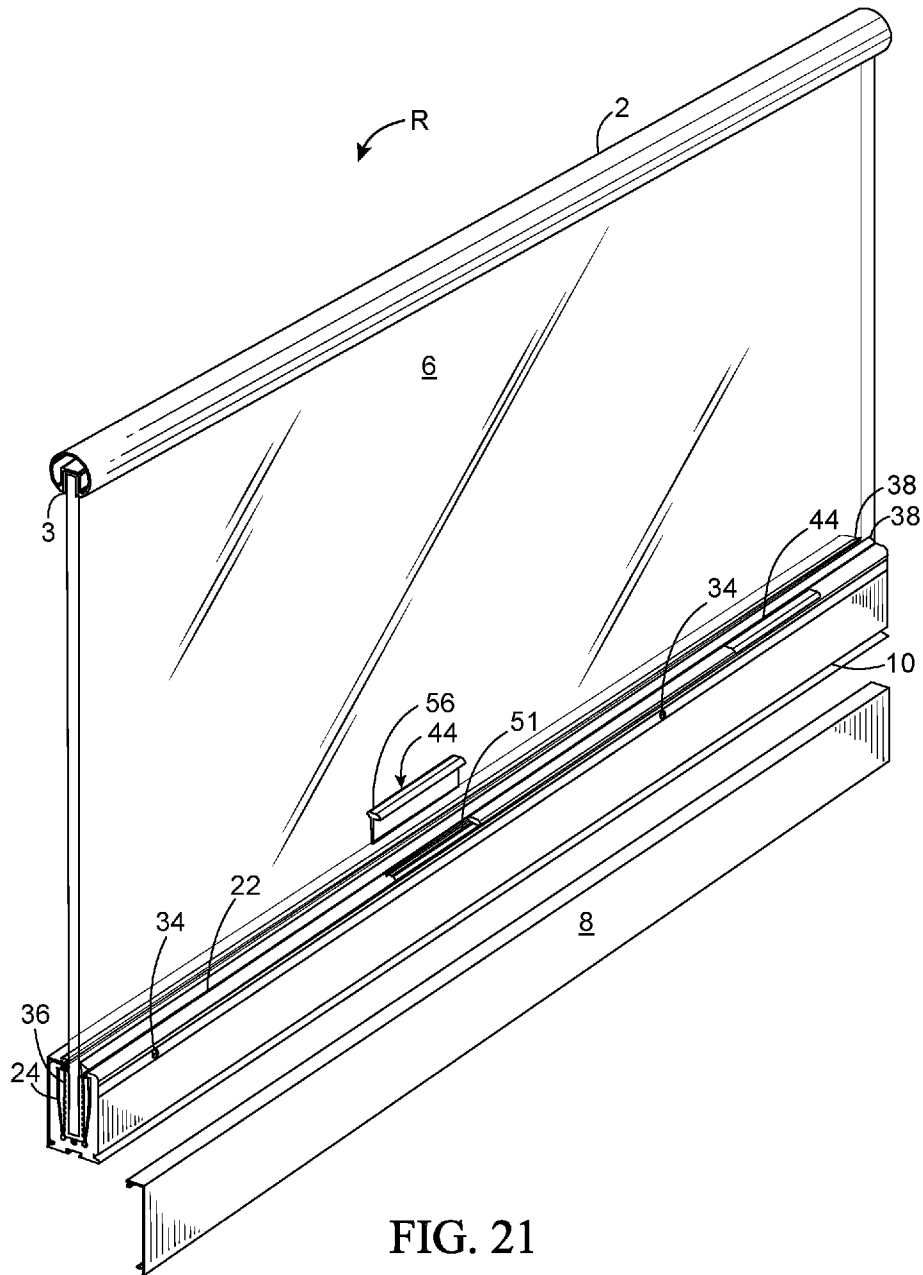

FIG. 21

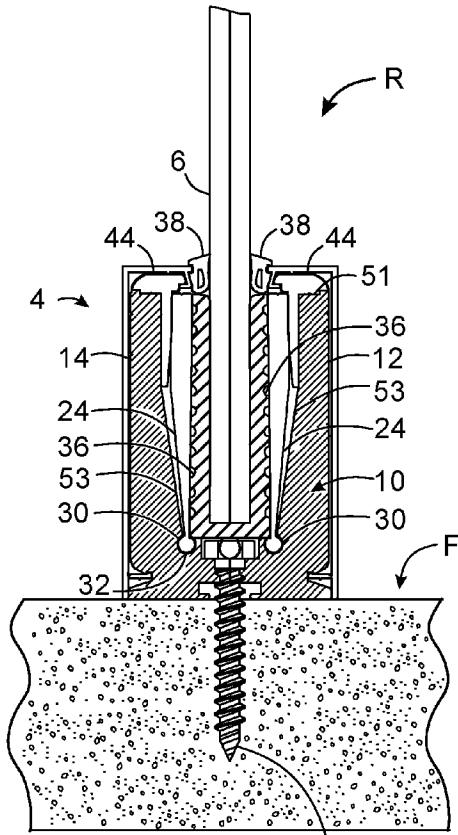

FIG. 22 18

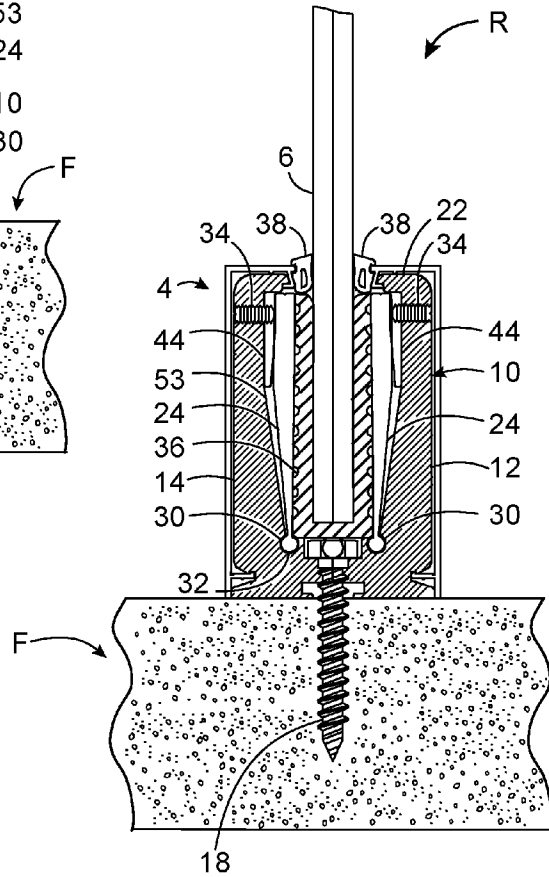

FIG. 23

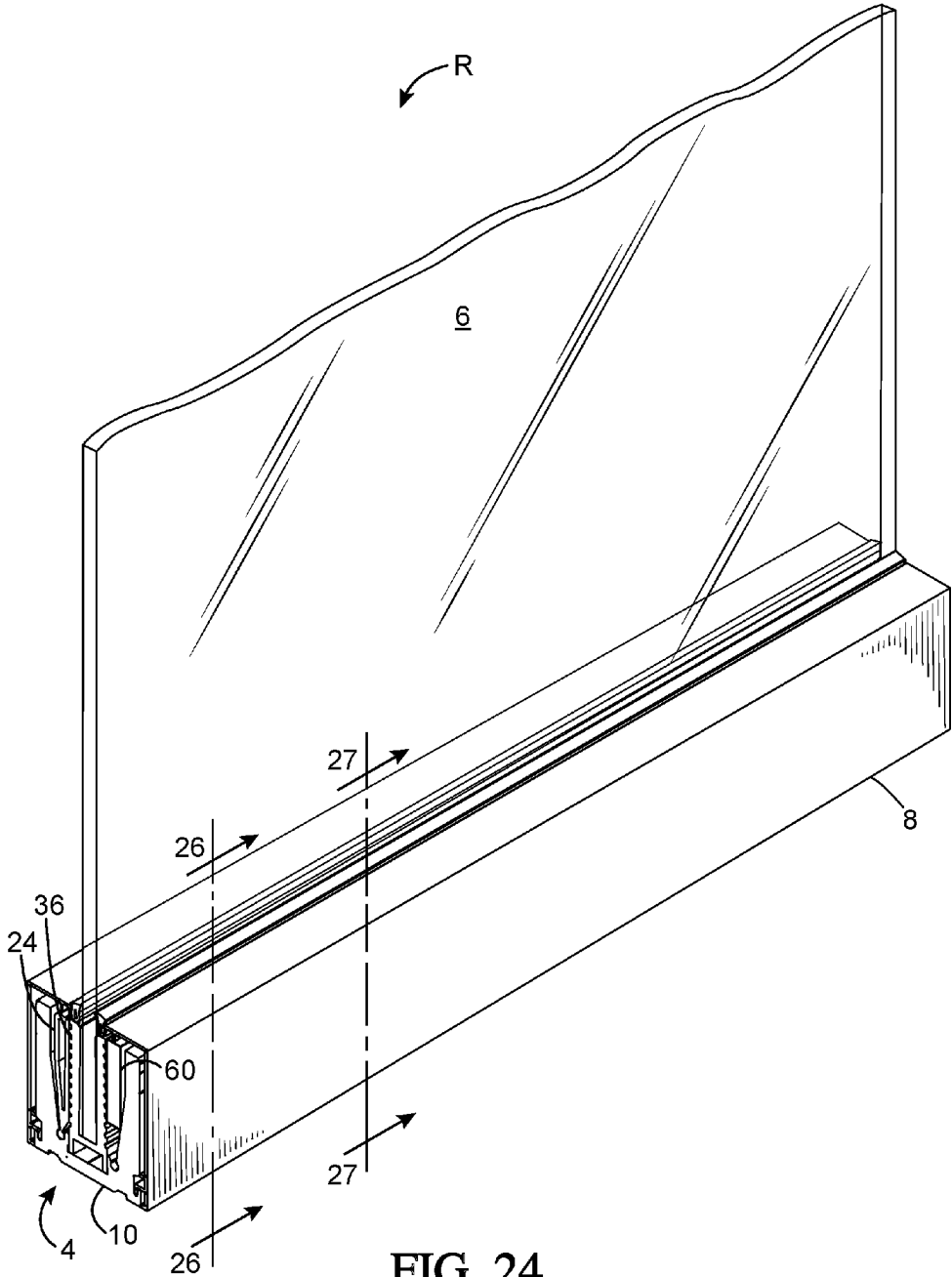

FIG. 24

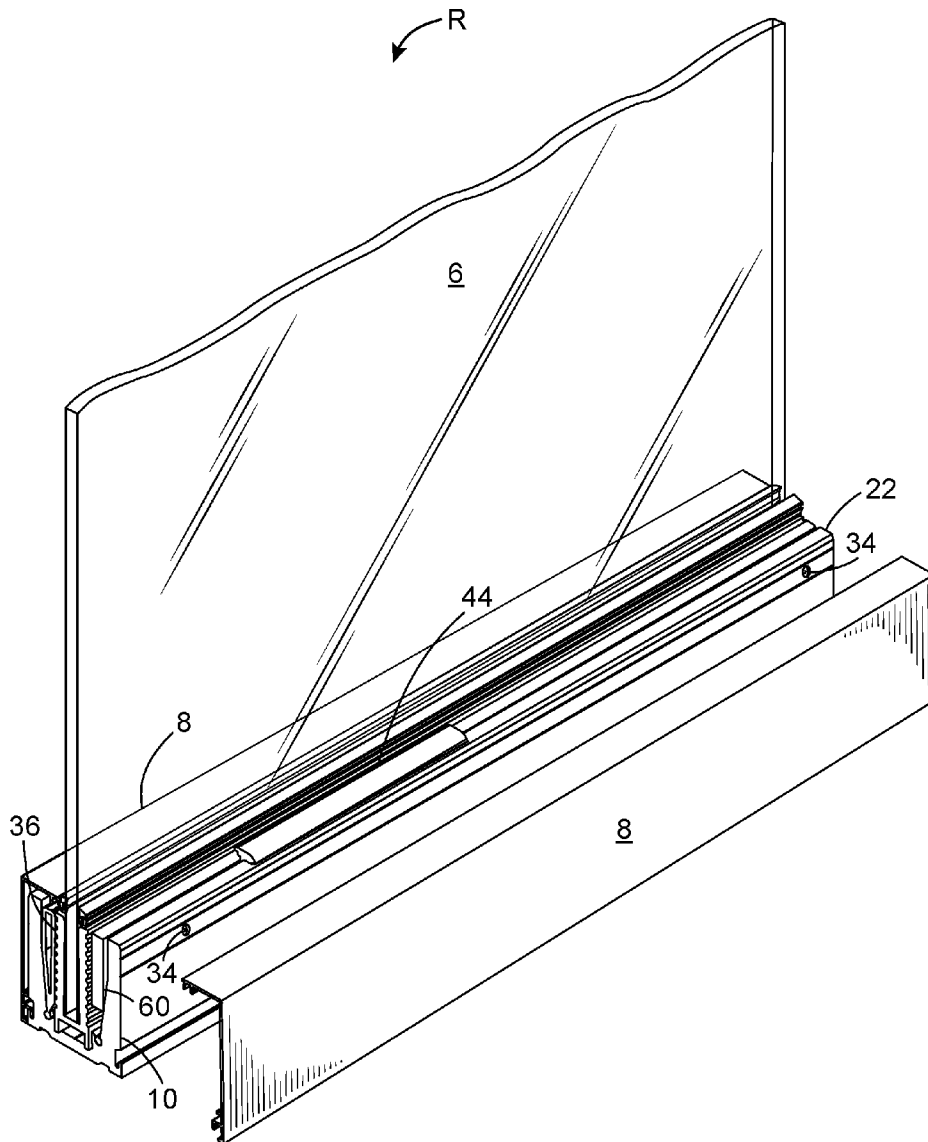

FIG. 25

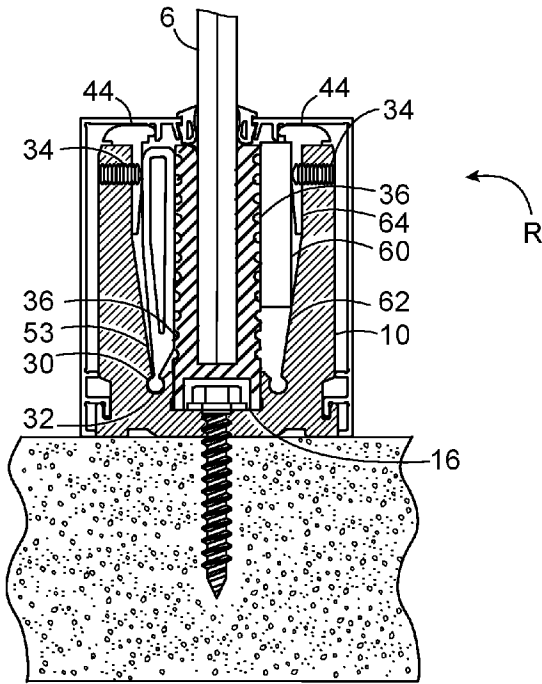

FIG. 26

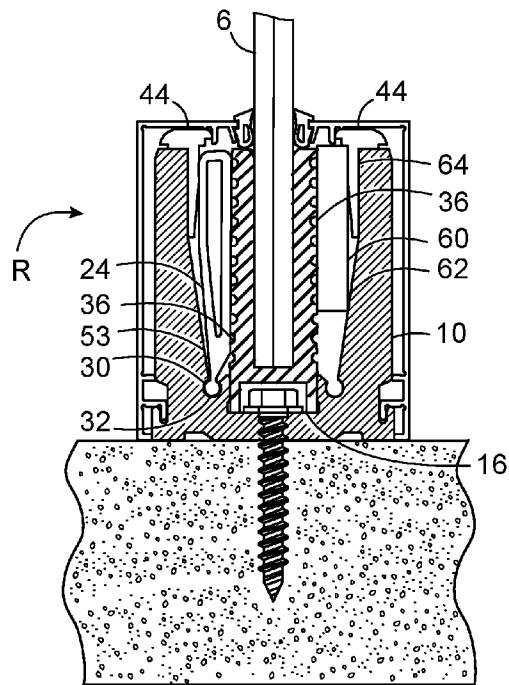

FIG. 27