



US009970231B2

(12) **United States Patent**  
**Header et al.**

(10) **Patent No.:** **US 9,970,231 B2**  
(45) **Date of Patent:** **\*May 15, 2018**

(54) **QUICK RELEASE CLADDING SYSTEM FOR FENESTRATION FRAMES**

(71) Applicant: **Gregory Header**, Pine Grove, PA (US)

(72) Inventors: **Gregory Header**, Richland, PA (US);  
**Anton Vassilev**, Lebanon, PA (US)

(73) Assignee: **Gregory Header**, Pine Grove, PA (US)

(\* ) Notice: Subject to any disclaimer, the term of this patent is extended or adjusted under 35 U.S.C. 154(b) by 0 days. days.

This patent is subject to a terminal disclaimer.

(21) Appl. No.: **15/431,232**

(22) Filed: **Feb. 13, 2017**

(65) **Prior Publication Data**

US 2017/0152699 A1 Jun. 1, 2017

**Related U.S. Application Data**

(63) Continuation of application No. 14/487,067, filed on Sep. 15, 2014, now Pat. No. 9,598,892.

(51) **Int. Cl.**

**E06B 3/30** (2006.01)

**E04F 19/02** (2006.01)

**E06B 1/34** (2006.01)

(52) **U.S. Cl.**

CPC ..... **E06B 3/303** (2013.01); **E04F 19/02** (2013.01); **E06B 1/34** (2013.01)

(58) **Field of Classification Search**

CPC ..... E06B 1/04; E06B 1/06; E06B 1/08; E06B 1/34; E06B 1/342; E06B 1/40; E06B 1/60; E06B 1/56; E06B 1/605; E06B 1/6023; E06B 3/9632; E06B 3/964; E06B

3/9647; E06B 3/968; E06B 3/9684; E06B 3/988; E04B 2/88; E04B 2/96; E04B 2/965; E04B 2/967; E04F 19/02; E04F 19/0459; E04F 19/0468; E04F 19/0472; E04F 19/0481; E04F 19/0495

See application file for complete search history.

(56) **References Cited**

U.S. PATENT DOCUMENTS

2,346,264 A 4/1944 Marshall

3,161,926 A 12/1964 Schaub

3,593,473 A 7/1971 King

(Continued)

FOREIGN PATENT DOCUMENTS

AU 641250 B2 1/1992

CA 1315603 C 4/1993

(Continued)

*Primary Examiner* — Jessica L Laux

(74) *Attorney, Agent, or Firm* — Stone Creek Services LLC; Alan M Flum

(57) **ABSTRACT**

Disclosed is quick-release removable cladding for interior fenestration frames, such as the interior frames of doors, window, skylights, or curtain walls. The cladding is held flush against the frame by a pair of brackets or alternatively by a bracket attached to frame and a shaped cavity within the cladding. In one aspect, the pair of brackets can be shaped and arranged so that when engaged, a downward force on the cladding causes the cladding to move flush against the frame. In another aspect, the cladding can be held securely in place to the frame by a keeper bar. The keeper bar can be configured to prevent upward movement of the cladding against the frame.

**10 Claims, 22 Drawing Sheets**

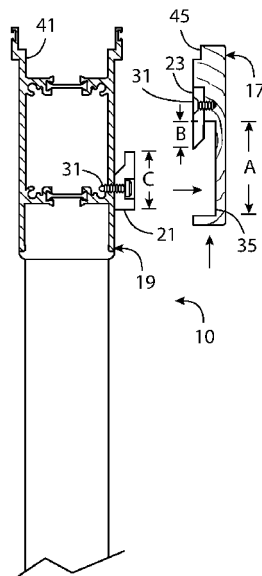

(56)

References Cited

U.S. PATENT DOCUMENTS

3,601,946 A \* 8/1971 Rothmund ..... E04B 2/967  
52/235

4,565,041 A 1/1986 Webdt

4,586,306 A 5/1986 Webb

4,621,471 A \* 11/1986 Kuhr ..... E04B 2/82  
52/242

4,694,612 A 9/1987 Pruden et al.

4,890,435 A 1/1990 Wilkening et al.

4,967,525 A 11/1990 Koester

4,982,530 A 1/1991 Palmer

5,081,793 A 1/1992 Mauro

5,224,610 A 7/1993 Veazy

5,253,459 A \* 10/1993 Parinas ..... E04B 2/96  
52/204.591

5,481,839 A 1/1996 Lang et al.

5,839,236 A 11/1998 Frey

6,141,923 A 11/2000 Habicht et al.

6,155,010 A 12/2000 Becken et al.

6,276,101 B1 8/2001 Schiedegger et al.

6,463,707 B1 10/2002 Schiedigger et al.

6,745,523 B2 6/2004 Petta

D621,075 S 8/2010 Haeussler

8,359,795 B2 1/2013 Beland

8,578,671 B2 11/2013 Labrecque et al.

8,631,619 B2 1/2014 Clayton et al.

8,769,901 B2 7/2014 Todd et al.

2002/0112423 A1 8/2002 Schiedegger et al.

2003/0145538 A1 \* 8/2003 Kerscher ..... E06B 1/34  
52/212

2006/0207197 A1 9/2006 Anderson

2008/0178541 A1 \* 7/2008 Kerscher ..... E06B 1/34  
52/204.1

2009/0064609 A1 3/2009 Ouyang et al.

2012/0233944 A1 9/2012 Reifer

2012/0241574 A1 9/2012 Uota et al.

2012/0272605 A1 11/2012 Huang

2012/0291391 A1 11/2012 MacDonald

2013/0180189 A1 7/2013 Reifer

2013/0312352 A1 11/2013 Gale

2013/0333321 A1 12/2013 Dollerup et al.

2014/0215939 A1 8/2014 Gosling et al.

2015/0197979 A1 7/2015 Hawk et al.

2015/0284951 A1 10/2015 Frederick

FOREIGN PATENT DOCUMENTS

CA 2643557 C 5/2009

CH 659679 A5 4/1986

CN 202755618 U 2/2013

CN 202755811 U 2/2013

CN 203034715 U 7/2013

CN 103470142 A 12/2013

CN 203613950 U 5/2014

CN 203613980 U 5/2014

DE 19748418 A1 5/1999

DE 10029744 A1 4/2001

DE 102012110546 A1 5/2014

EP 53104 A 6/1982

EP 517057 A2 12/1992

EP 987396 A2 3/2000

EP 1091075 A1 4/2001

EP 1338746 A2 8/2003

FR 2440459 A1 5/1980

FR 2910509 A1 6/2008

GB 1054925 A 1/1967

GB 2251645 A 7/1992

GB 2233682 B 11/1993

GB 2468161 A 9/2010

KR 100740254 B1 7/2007

WO 1001544 C2 2/2010

\* cited by examiner

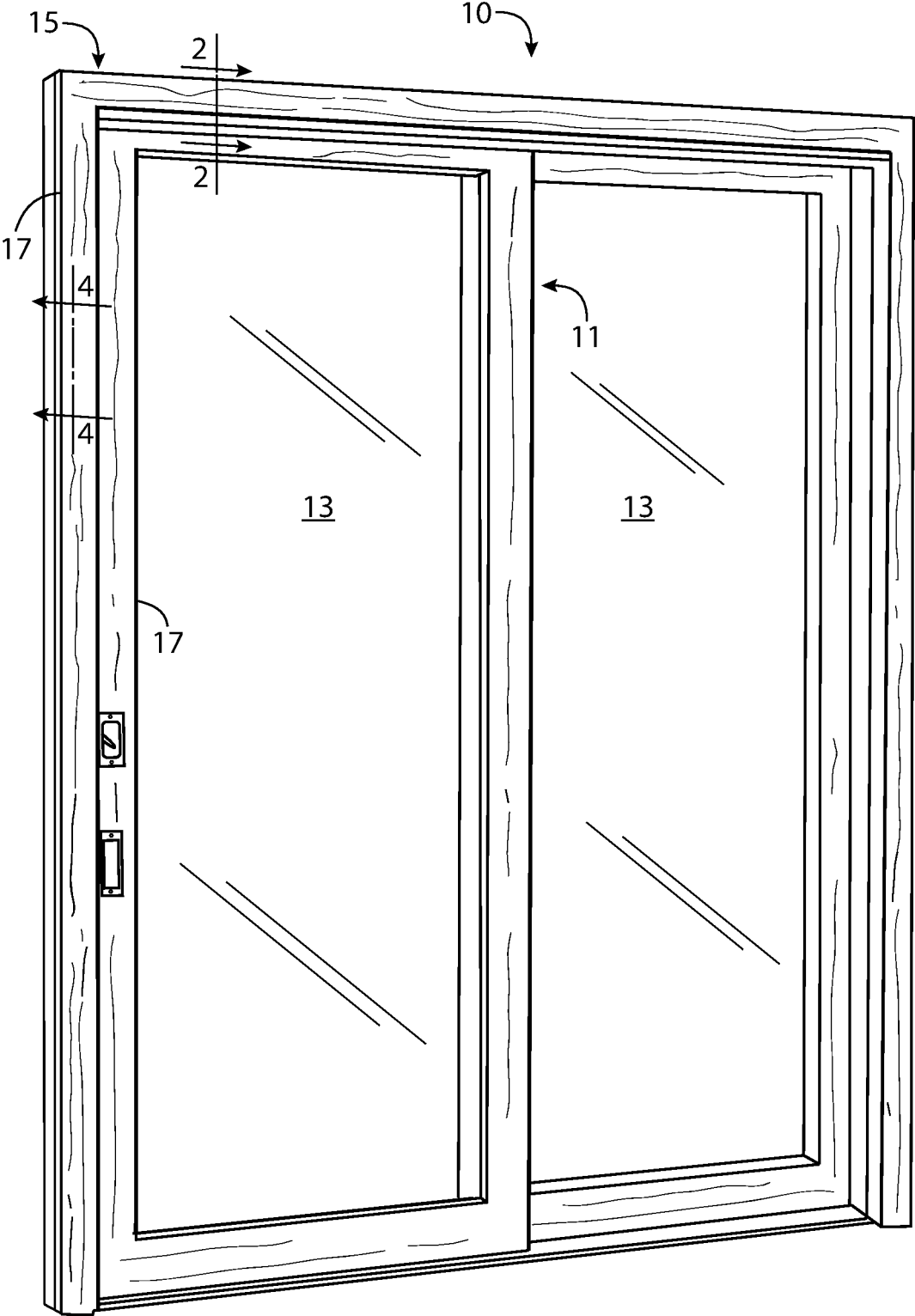

FIG.1

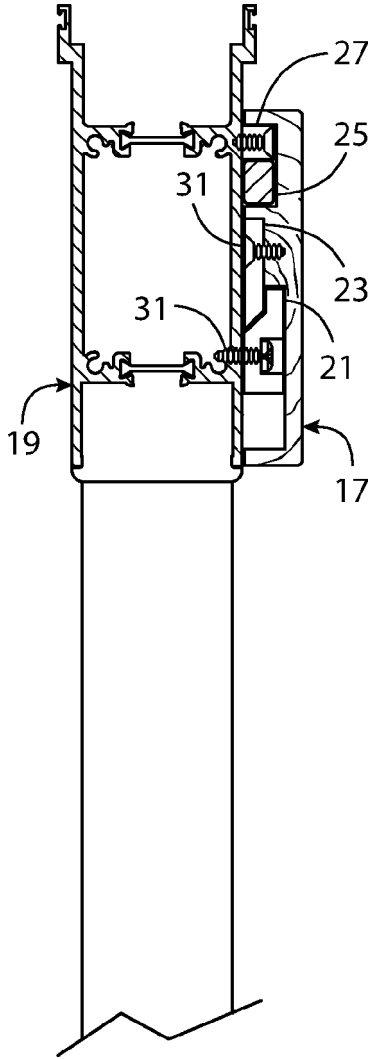

FIG. 2

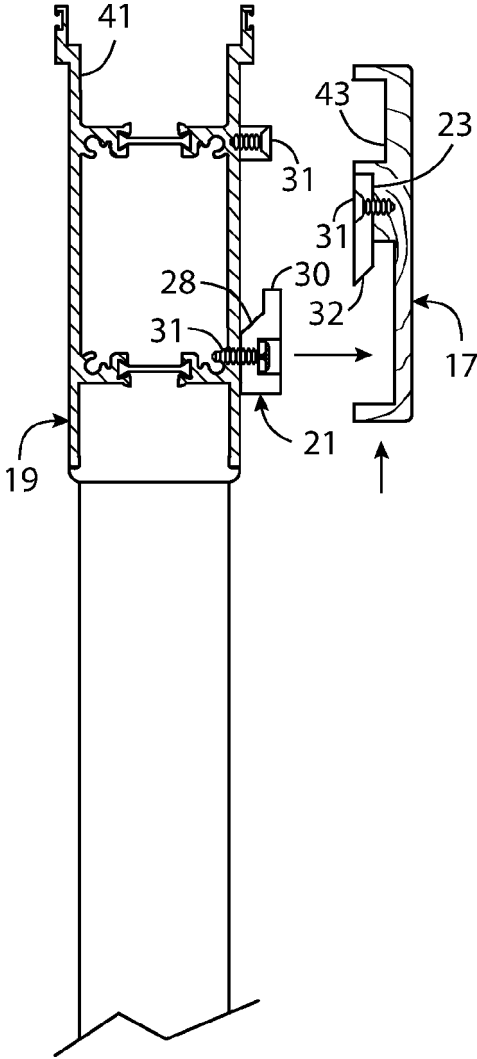

FIG. 3

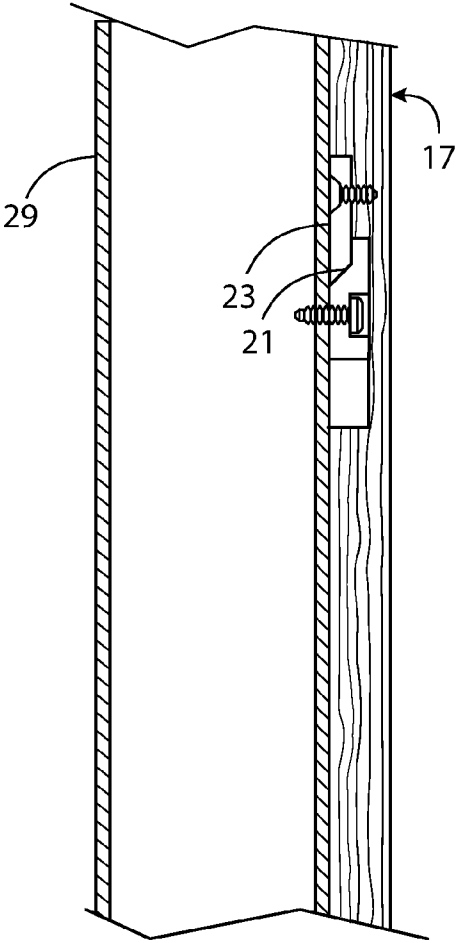

FIG. 4

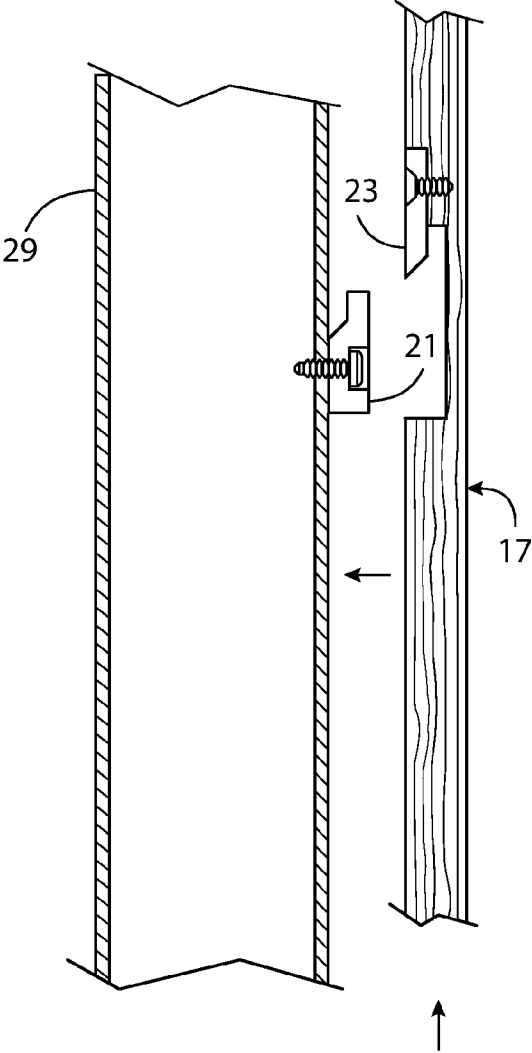

FIG. 5

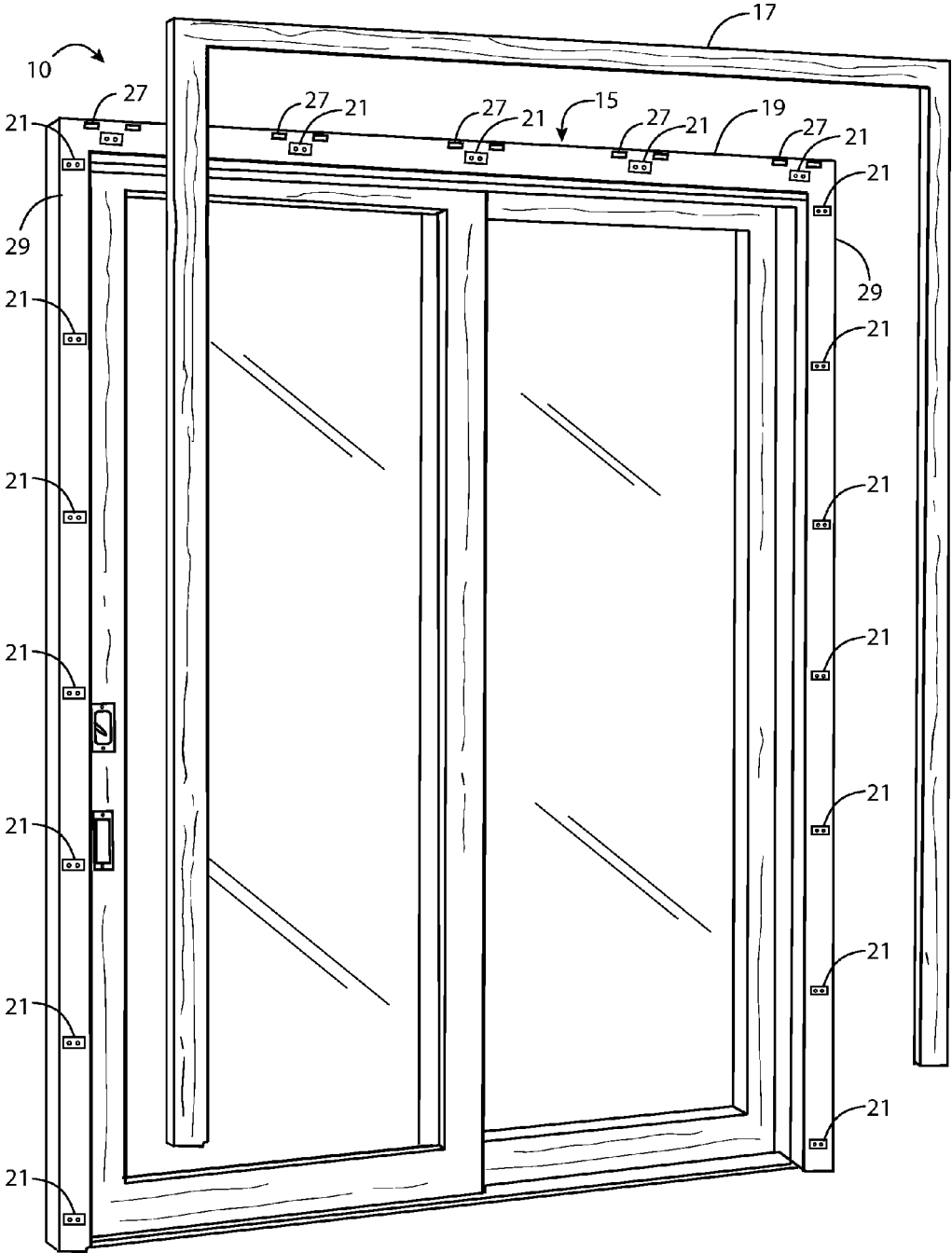

FIG. 6

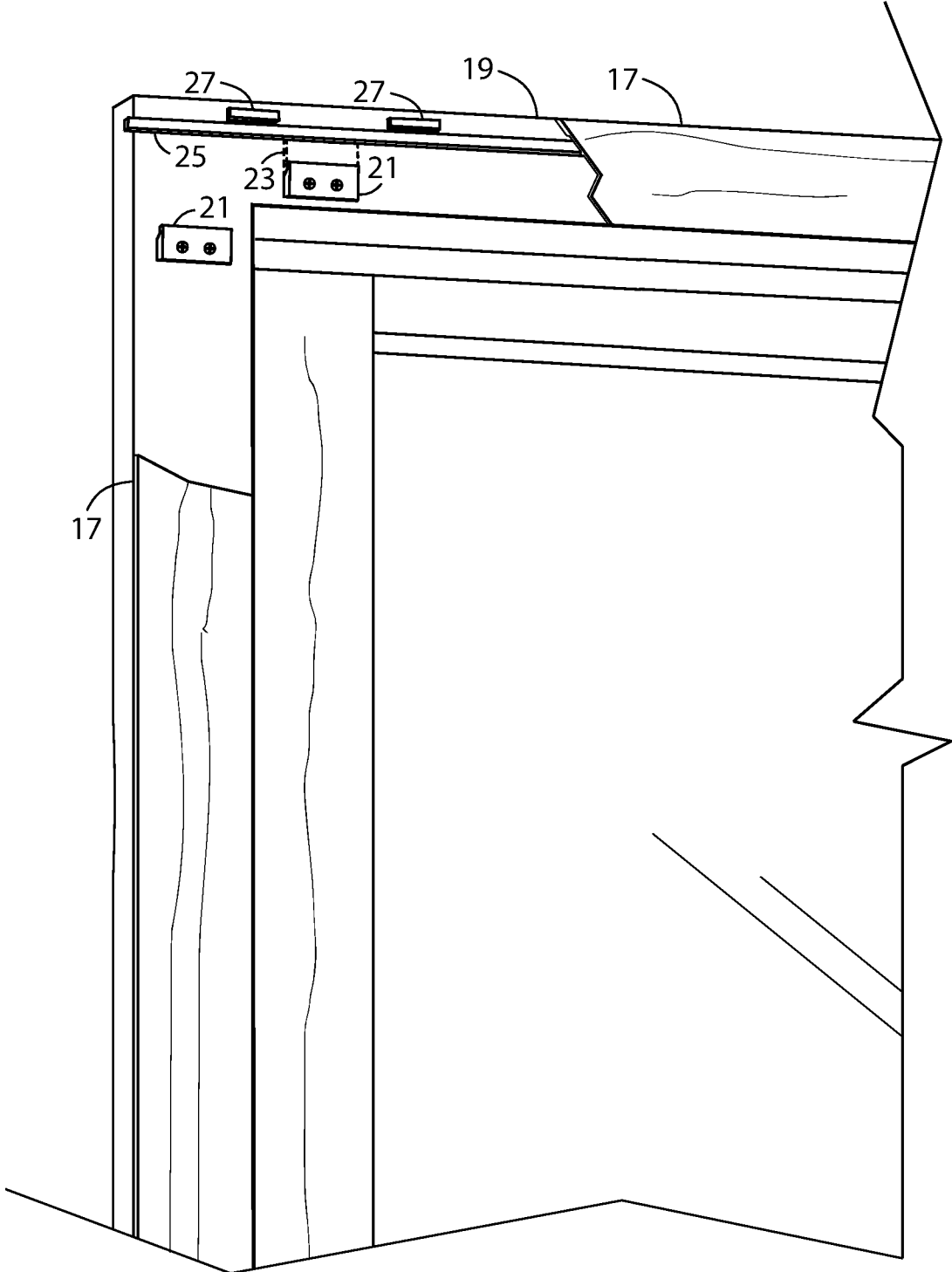

FIG. 7

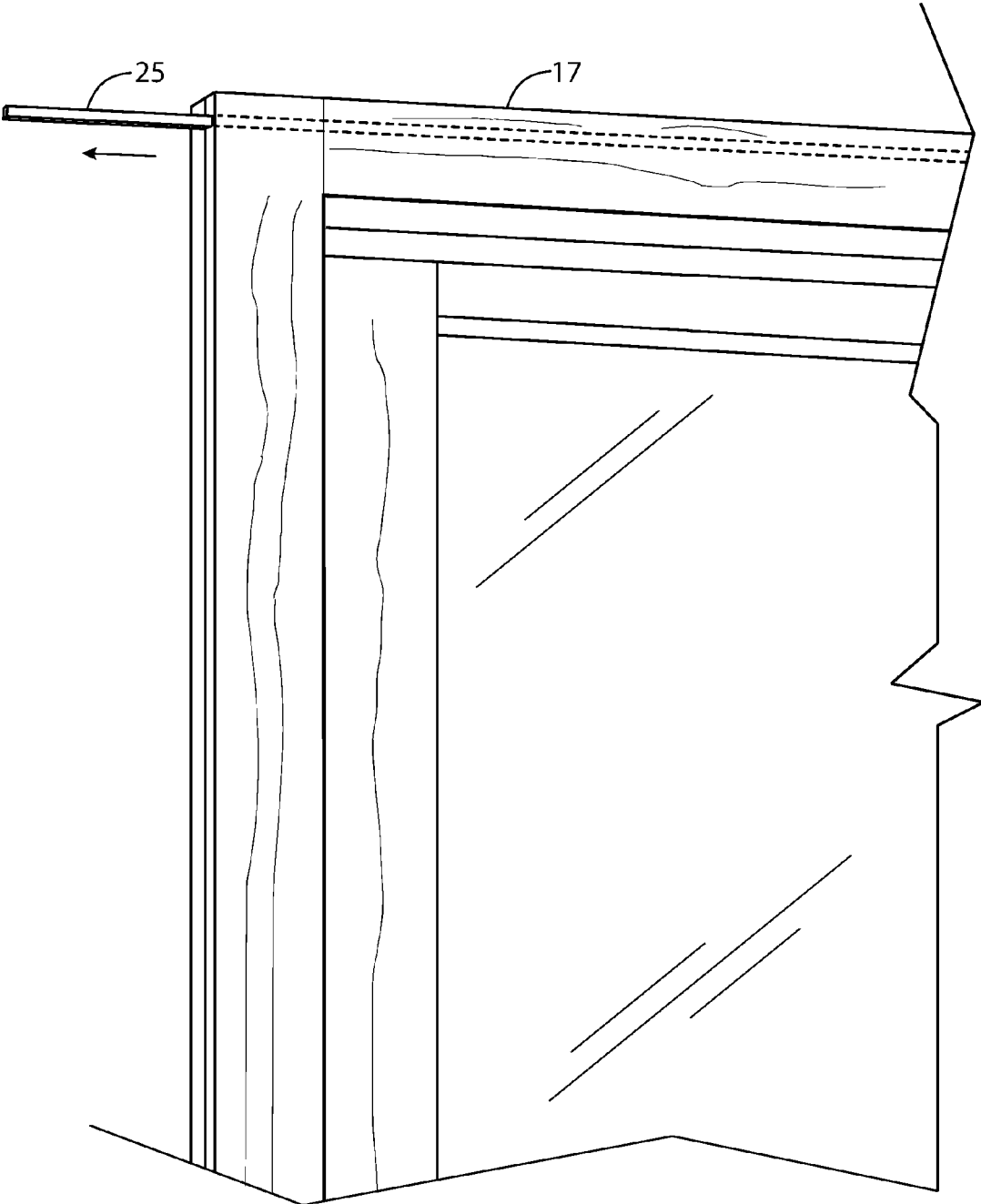

FIG. 8



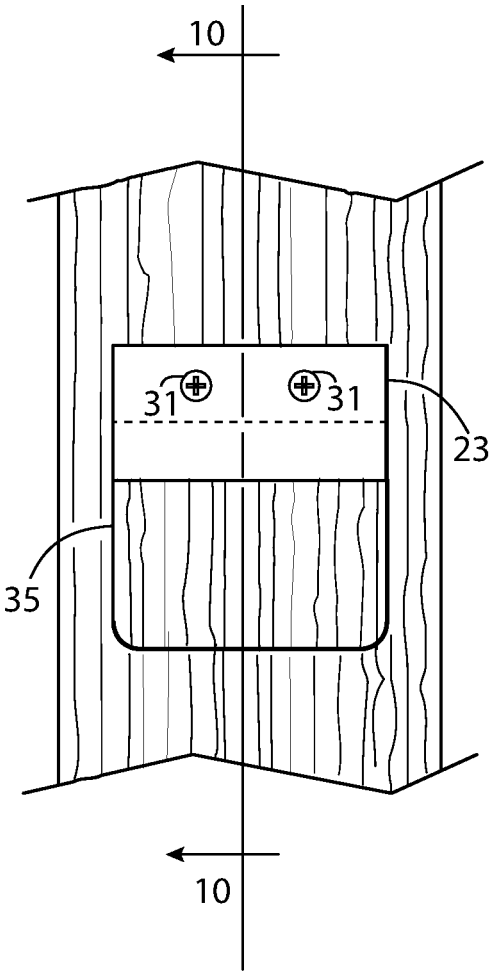

FIG. 9

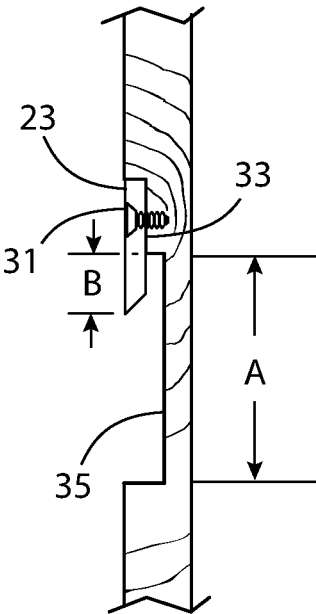

FIG. 10

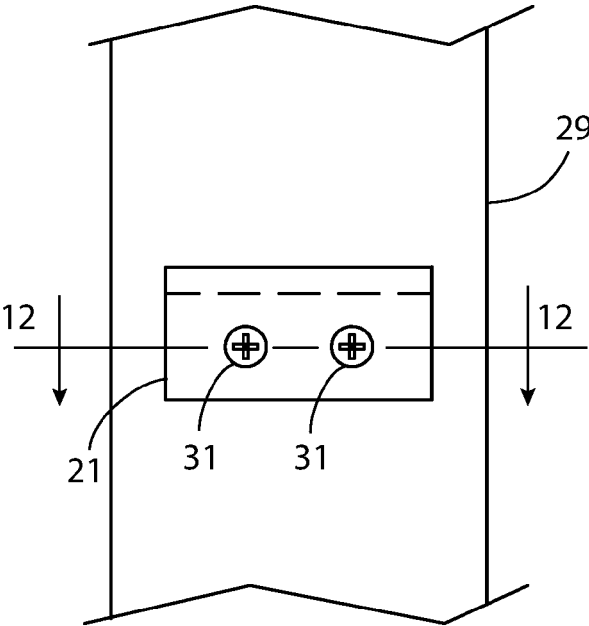

FIG. 11

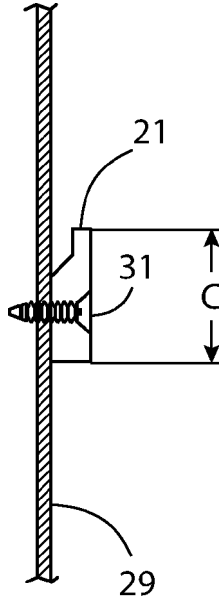

FIG. 13

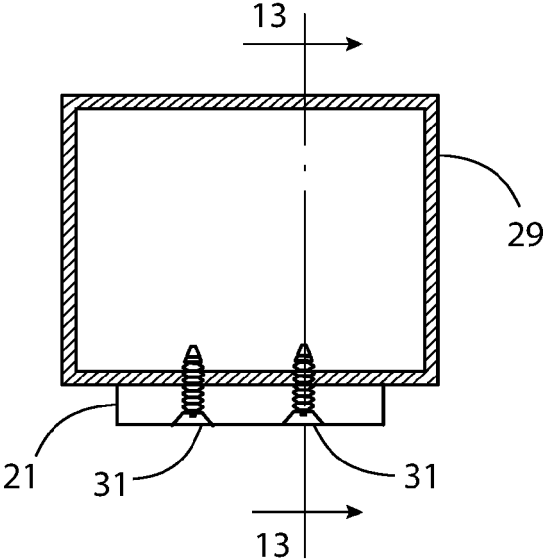

FIG. 12

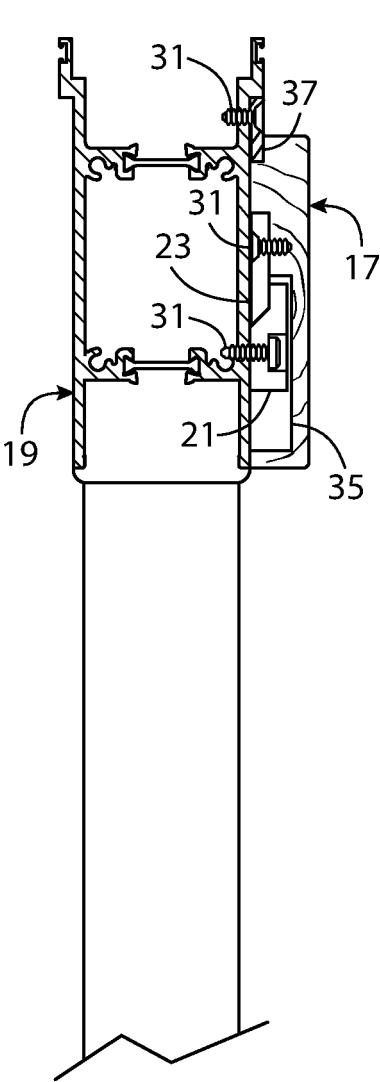

FIG. 14

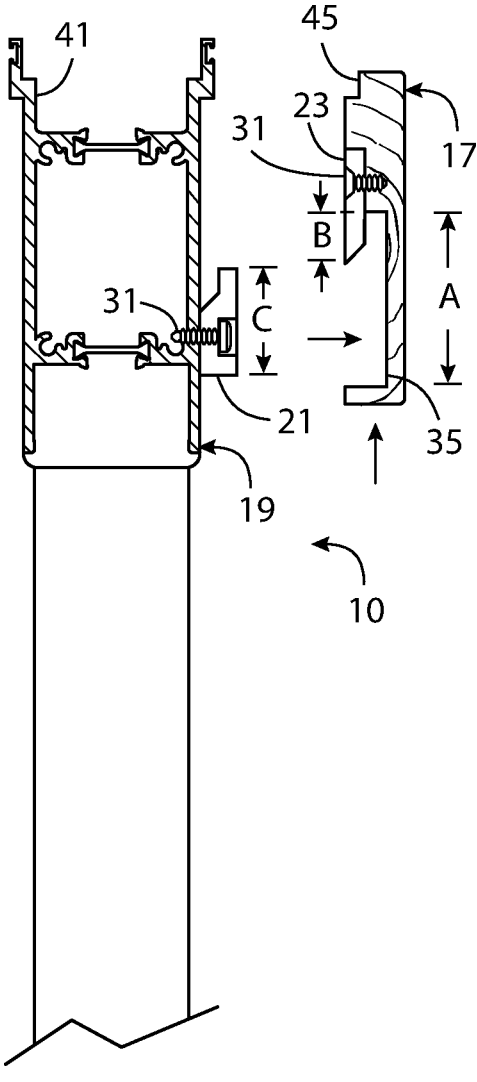

FIG. 15

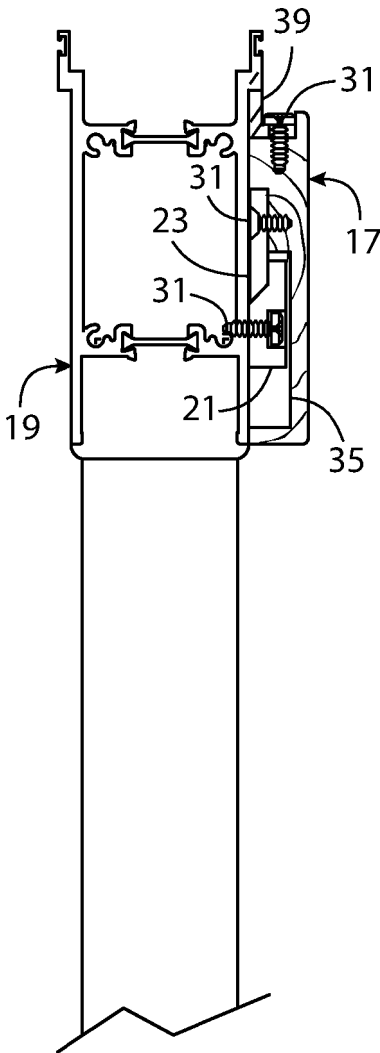

FIG. 16

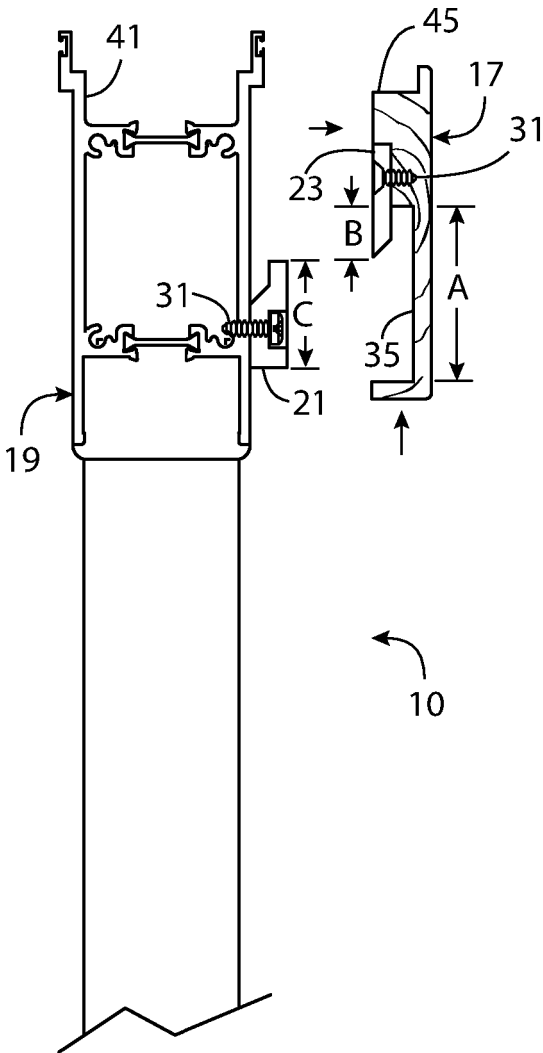

FIG. 17

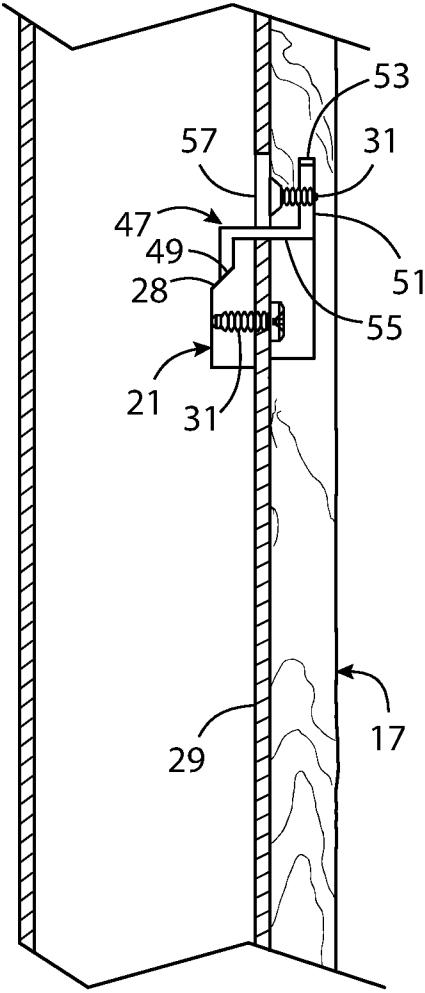

FIG. 18

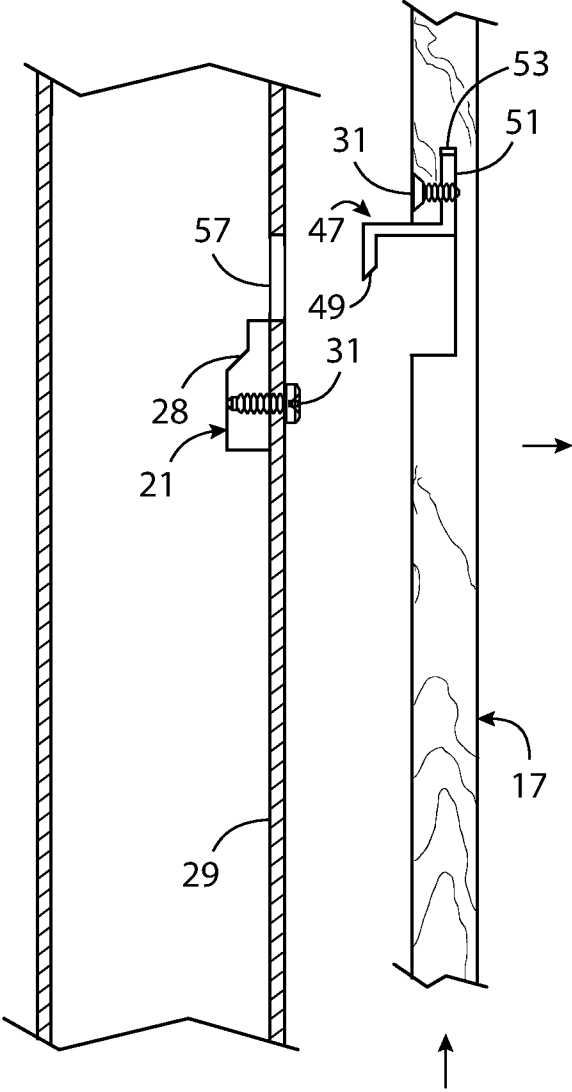

FIG. 19

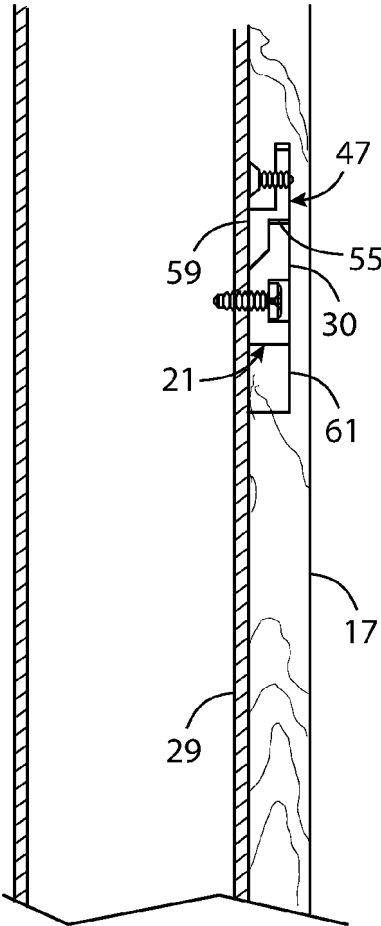

FIG. 20

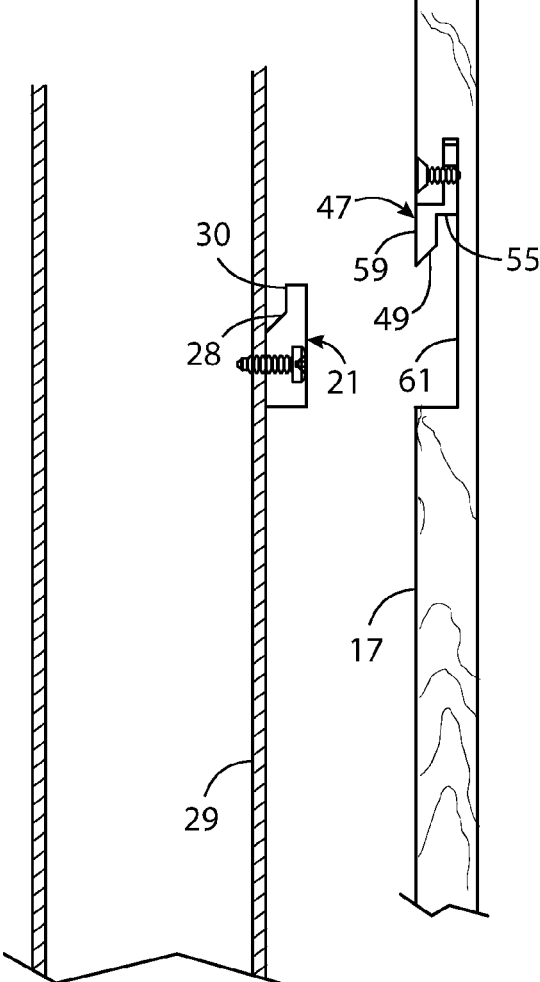

FIG. 21

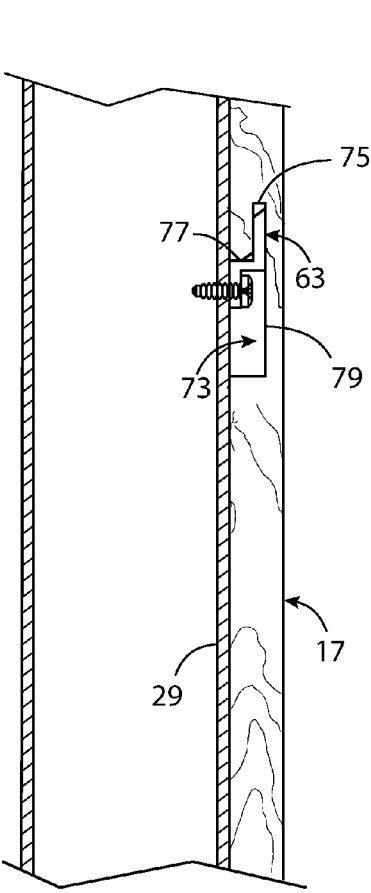

FIG. 22

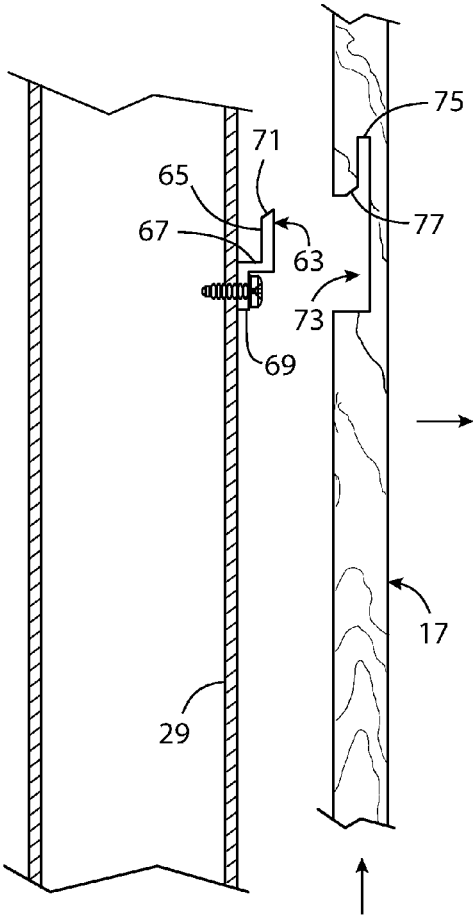

FIG. 23

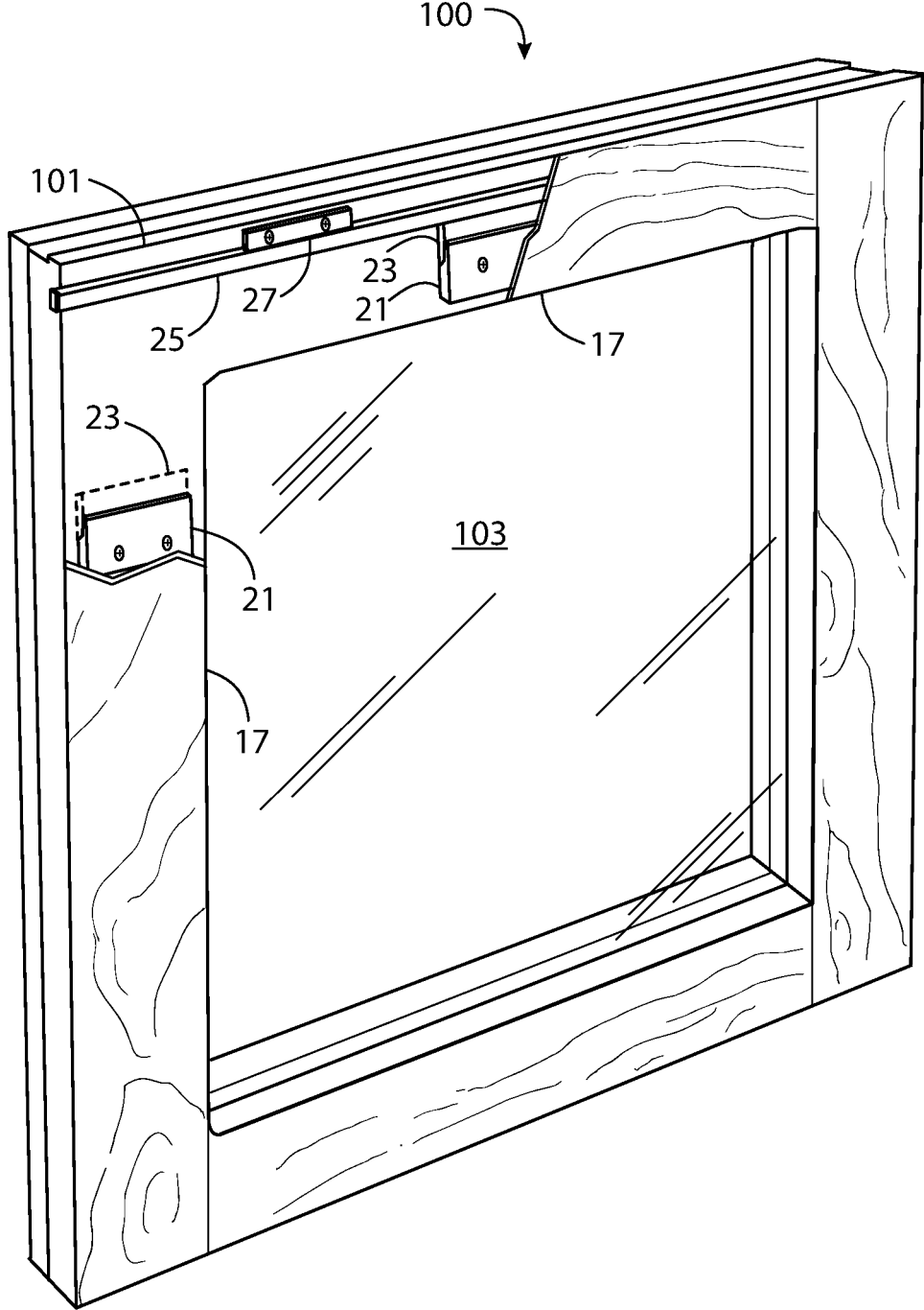

FIG. 24



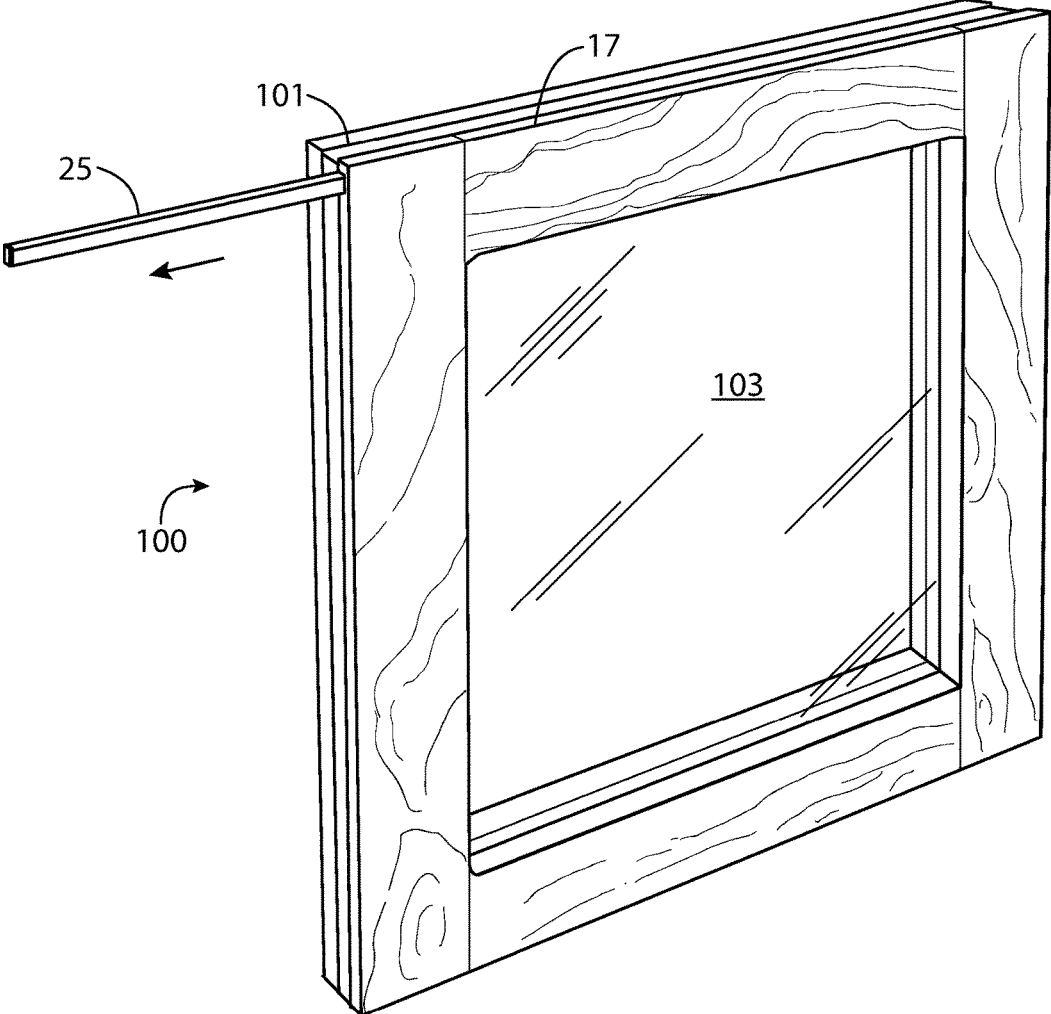

FIG. 25

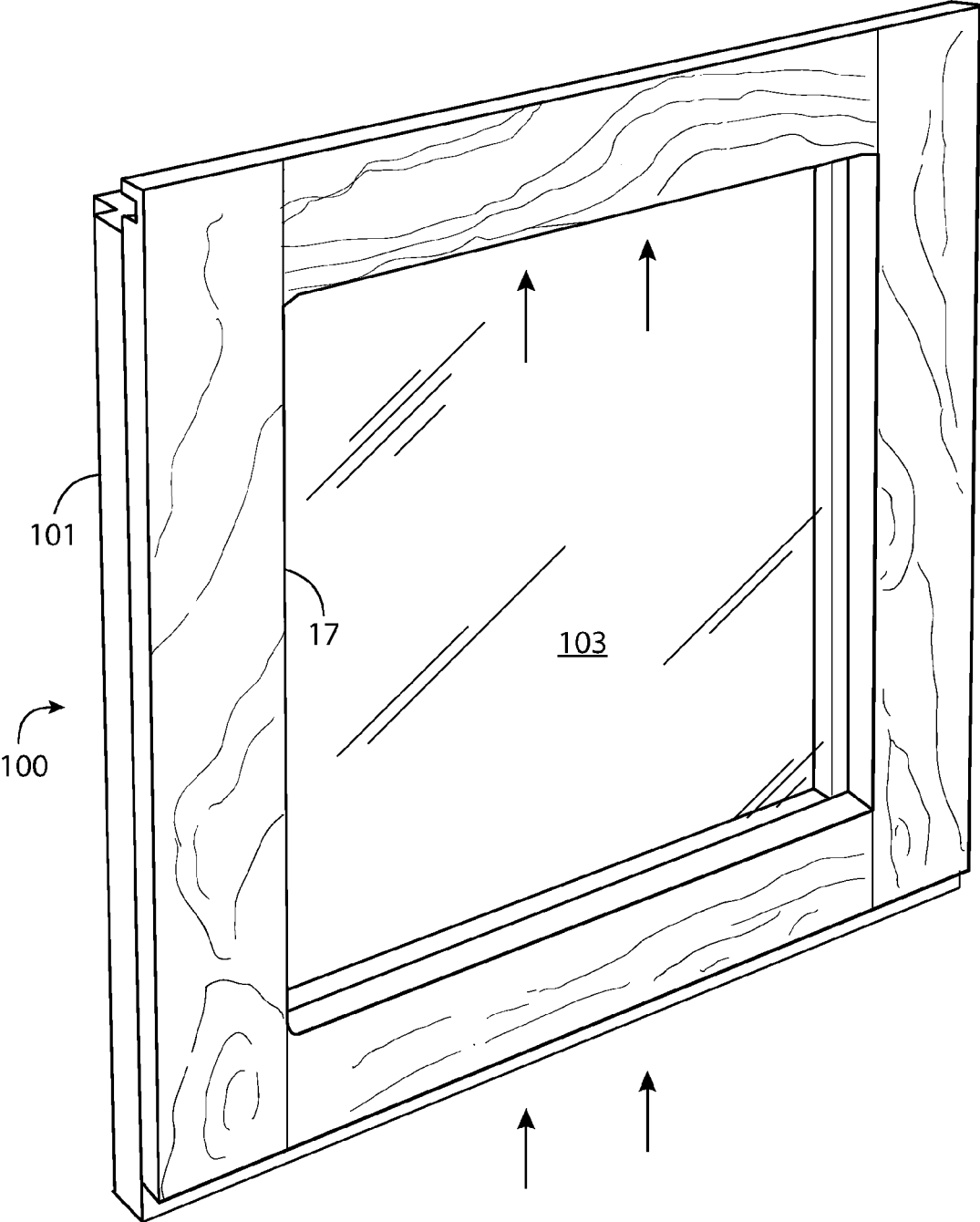

FIG. 26

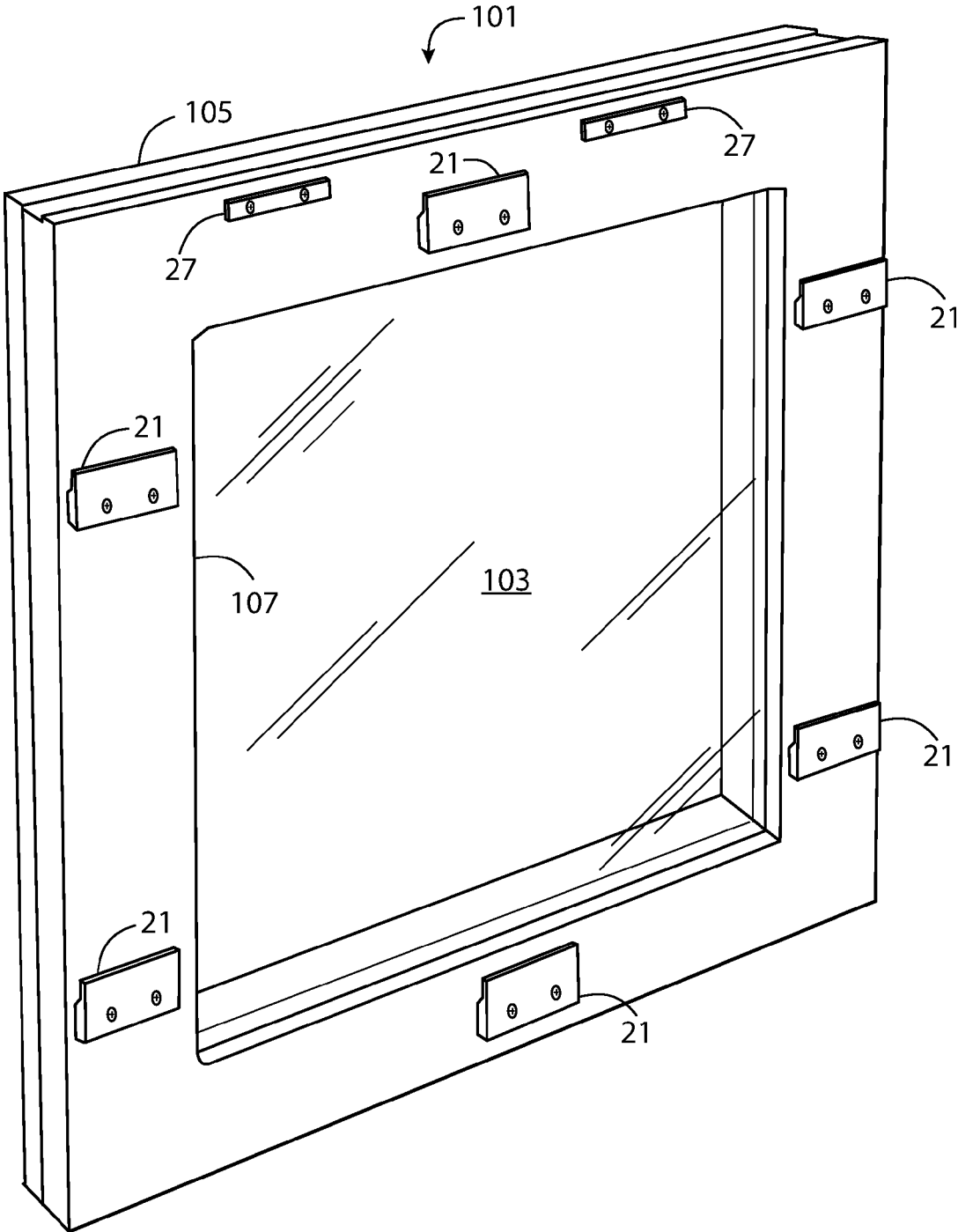

FIG. 27

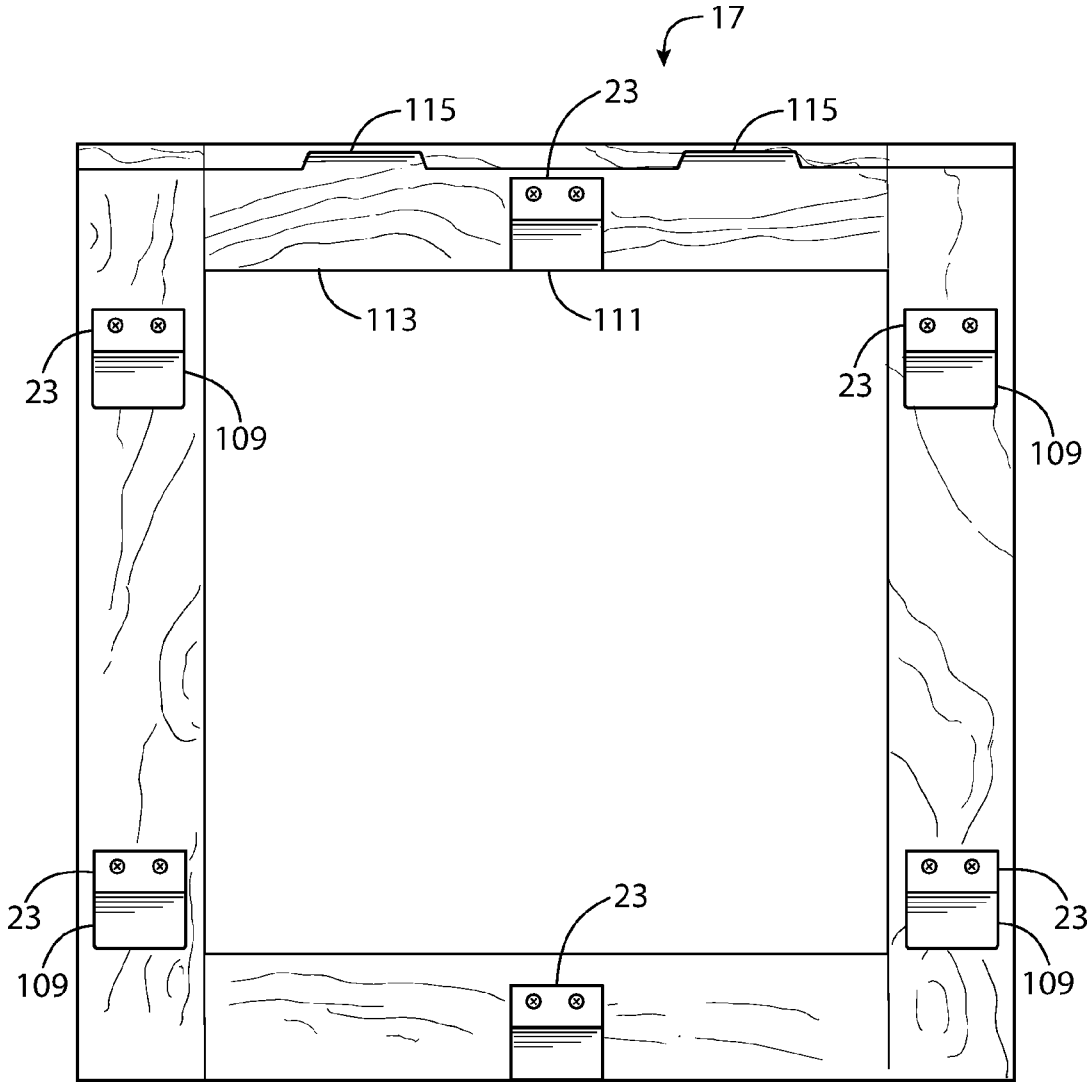

FIG. 28

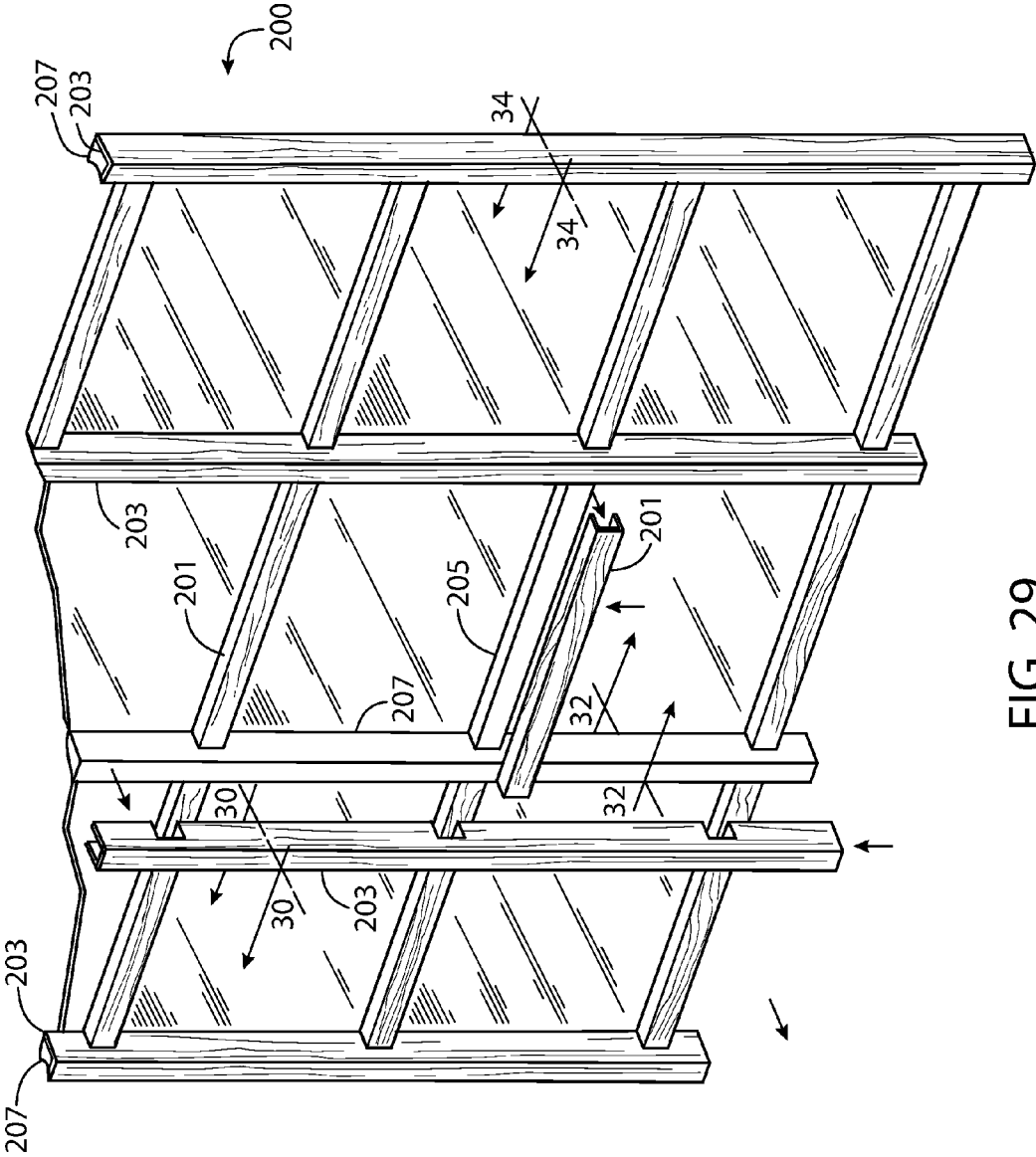

FIG. 29

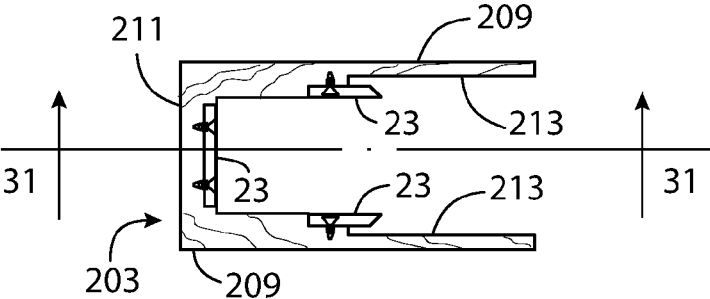

FIG. 30

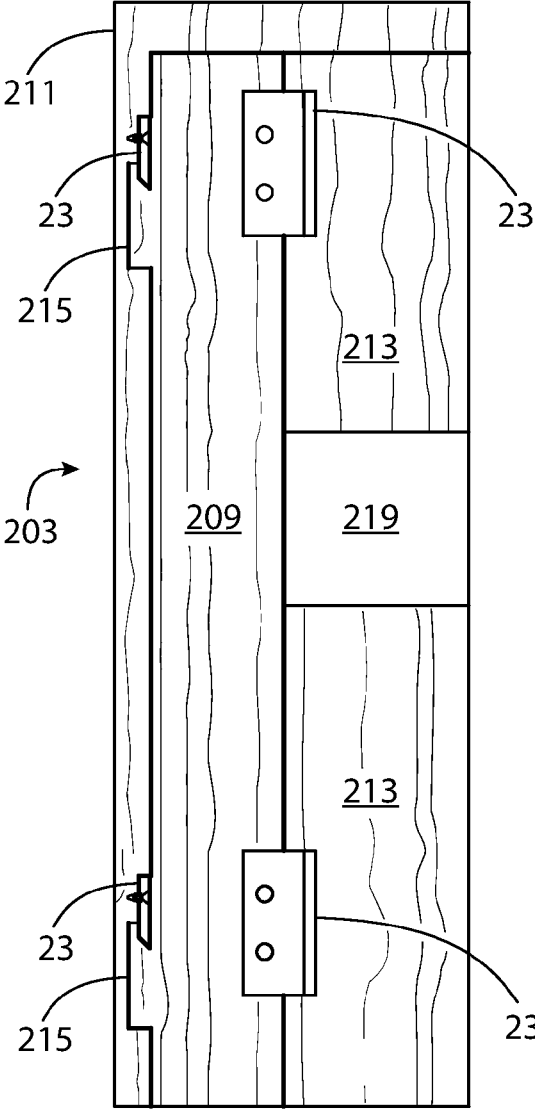

FIG. 31

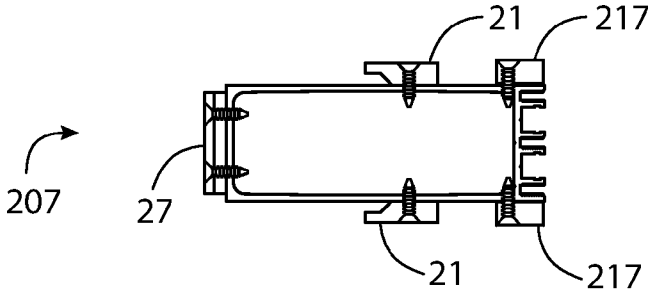

FIG. 32

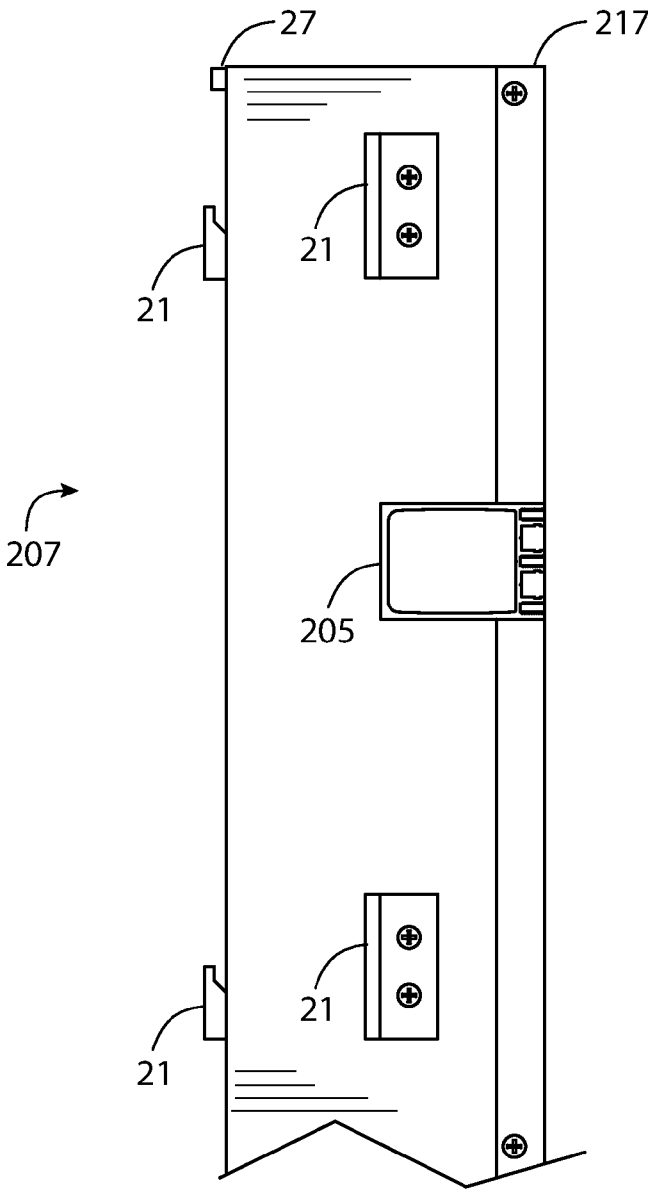

FIG. 33

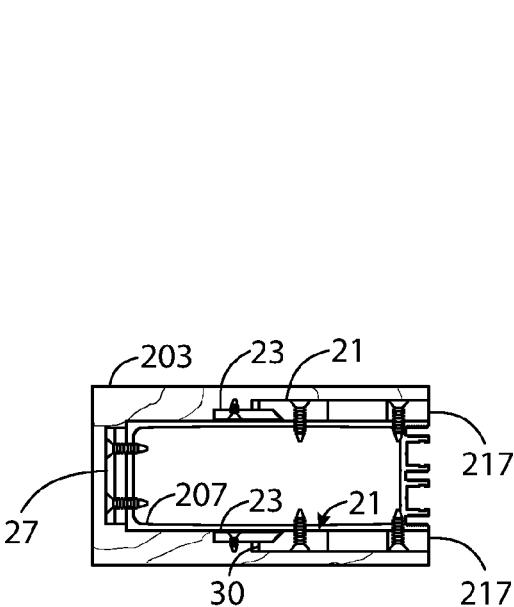

FIG. 34

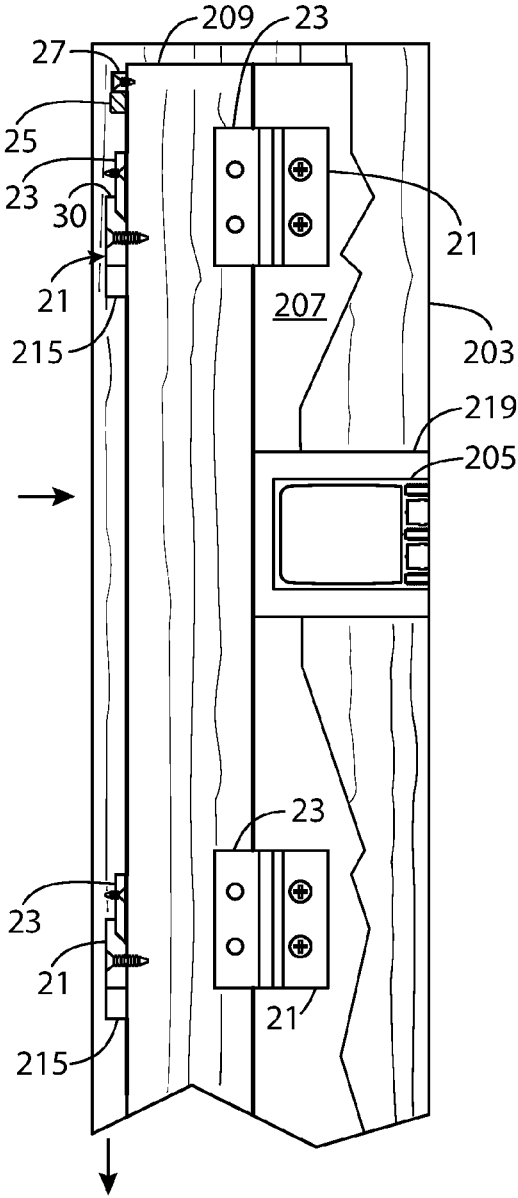

FIG. 35